

# INSTALLATION INSTRUCTIONS

## SERIES 650-T, 700-T, AND 750-T HIGH PERFORMANCE ENTRANCE DOORS

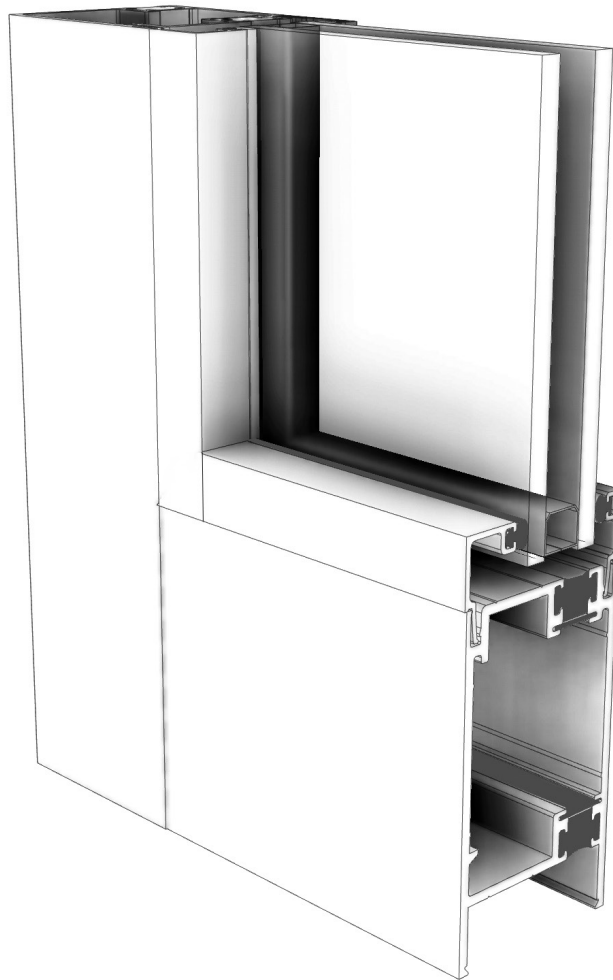

---

Phone: (800) 262-5151 • Fax: (866) 262-3299  
crlaurence.com • usalum.com • crl-arch.com

---

# HANDLING, STORAGE, AND PROTECTION OF ALUMINUM

The following precautions are recommended to protect the material against damage. Following these precautions will help ensure early acceptance of your products and workmanship.

**A. HANDLE CAREFULLY.**

All aluminum materials at job site must be stored in a safe place, well removed from possible damage by other trades. Cardboard wrapped or paper interleaved materials must be kept dry.

**B. CHECK ARRIVING MATERIALS.**

Check for quantity counts and keep records of where various materials are stored.

**C. KEEP MATERIALS AWAY FROM WATER, MUD, AND SPRAY.**

Prevent cement, plaster, or other materials from damaging the finish.

**D. PROTECT THE MATERIALS AFTER ERECTION.**

Protect erected frame with polyethylene or canvas splatter screen. Cement, plaster, terrazzo, other alkaline solutions, and acid based materials used to clean masonry are harmful to the finish. ***If any of these materials come in contact with the aluminum, immediately remove with water and mild soap.***

The rapidly changing technology within the architectural aluminum products industry demands that C. R. Laurence/U.S. Aluminum reserve the right to revise, discontinue, or change any product line, specification, or electronic media without prior written notice.

**NOTE:** Dimensions in parentheses ( ) are millimeters unless otherwise noted.

# GENERAL INSTALLATION NOTES

## Recommended Guidelines For All Installations:

- 1. REVIEW CONTRACT DOCUMENTS.** Check shop drawings, installation instructions, architectural drawings and shipping lists to become thoroughly familiar with the project. The shop drawings take precedence and include specific details for the project. Note any **field verified** notes on the shop drawings prior to installing. The installation instructions are of a general nature and cover most conditions.
- 2. INSTALLATION.** All materials are to be installed plumb, level, and true.
- 3. BENCH MARKS.** All work should start from bench marks and/or column lines as established by the architectural drawings and the general contractor with guaranteed accuracy. Working from these datum points and lines determine:
  - a) The plane of the wall in reference to offset lines provided on each floor.
  - b) The finish floor lines in reference to bench marks on the outer building columns.
  - c) Mullion spacing from both ends of masonry opening to prevent dimensional build-up of daylight opening.
- 4. FIELD WELDING.** All field welding must be adequately shielded to avoid any splatter on glass or aluminum. Results will be unsightly and/or structurally unsound. Advise general contractor and other trades accordingly. All field welds of steel anchors must receive touch-up paint (zinc chromate) to avoid rust.
- 5. SURROUNDING CONDITIONS.** Make certain that construction which will receive your materials is in accordance with the contract documents. If not, notify the general contractor in writing and resolve differences before proceeding with work.
- 6. ISOLATION OF ALUMINUM.** Aluminum to be placed in direct contact with uncured masonry or incompatible materials should be isolated with a heavy coat of zinc chromate or bituminous paint.
- 7. SEALANTS.** Sealants must be compatible with all materials with which they have contact, including other sealant surfaces. Consult with sealant manufacturer for recommendations relative to joint size, shelf life, compatibility, cleaning/priming, tooling, adhesion, etc. It is the responsibility of the **Glazing Contractor** to submit a statement from the sealant manufacturer indicating that glass and glazing materials have been tested for compatibility and adhesion with glazing sealants, and interpreting test results relative to material performance, including recommendations for primers and substrate preparation required to obtain adhesion. The chemical compatibility of all glazing materials and framing sealants with each other and with like materials used in glass fabrication must be established. **This is required on every project.**
- 8. FASTENING.** Within the body of these instructions "fastening" means any method of securing one part to another or to adjacent materials. Only those fasteners used within the system are specified in these instructions. Due to the varying perimeter conditions and performance requirements, perimeter and anchor fasteners are not specified in these instructions. For perimeter and anchor fasteners refer to the shop drawings or consult the fastener supplier.
- 9. BUILDING CODES.** Due to the diversity in state/provincial, local, and federal laws and codes that govern the design and application of architectural products, it is the responsibility of the individual, architect, owner, and installer to assure that products selected for use on projects comply with all the applicable building codes and laws. U.S. Aluminum exercises no control over the use or application of its products, glazing materials, and operating hardware, and assumes no responsibility thereof.
- 10. EXPANSION JOINTS.** Expansion joints and perimeter seals shown in these instructions and in the shop drawings are shown at normal size. Actual dimensions may vary due to perimeter conditions and/or difference in metal temperature between the time of fabrication and the time of installation. Gap between expansion members should be based on temperature at time of installation.
- 11. WATER HOSE TEST.** As soon as a representative amount of the wall has been glazed (500 square feet or 46.5 m<sup>2</sup>) a water hose test should be conducted in accordance with AAMA 501.2 specifications to check the installation. On all jobs the hose test should be repeated every 500 square feet (46.5 m<sup>2</sup>) during the glazing operation.
- 12. COORDINATION WITH OTHER TRADES.** Coordinate with the general contractor any sequence with other trades which offset curtain wall installation (i.e. fire proofing, back-up walls, partitions, ceilings, mechanical ducts, converters, etc.).
- 13. CARE AND MAINTENANCE.** Final cleaning of exposed aluminum surfaces should be done in accordance with AAMA 609.1 for anodized aluminum and 610.1 for painted aluminum.

# FRAME UNIT FOR BUTT HUNG DOOR WITH SURFACE CLOSER

IT422 FRAME SHOWN  
IT455 AND TT461 SIMILAR

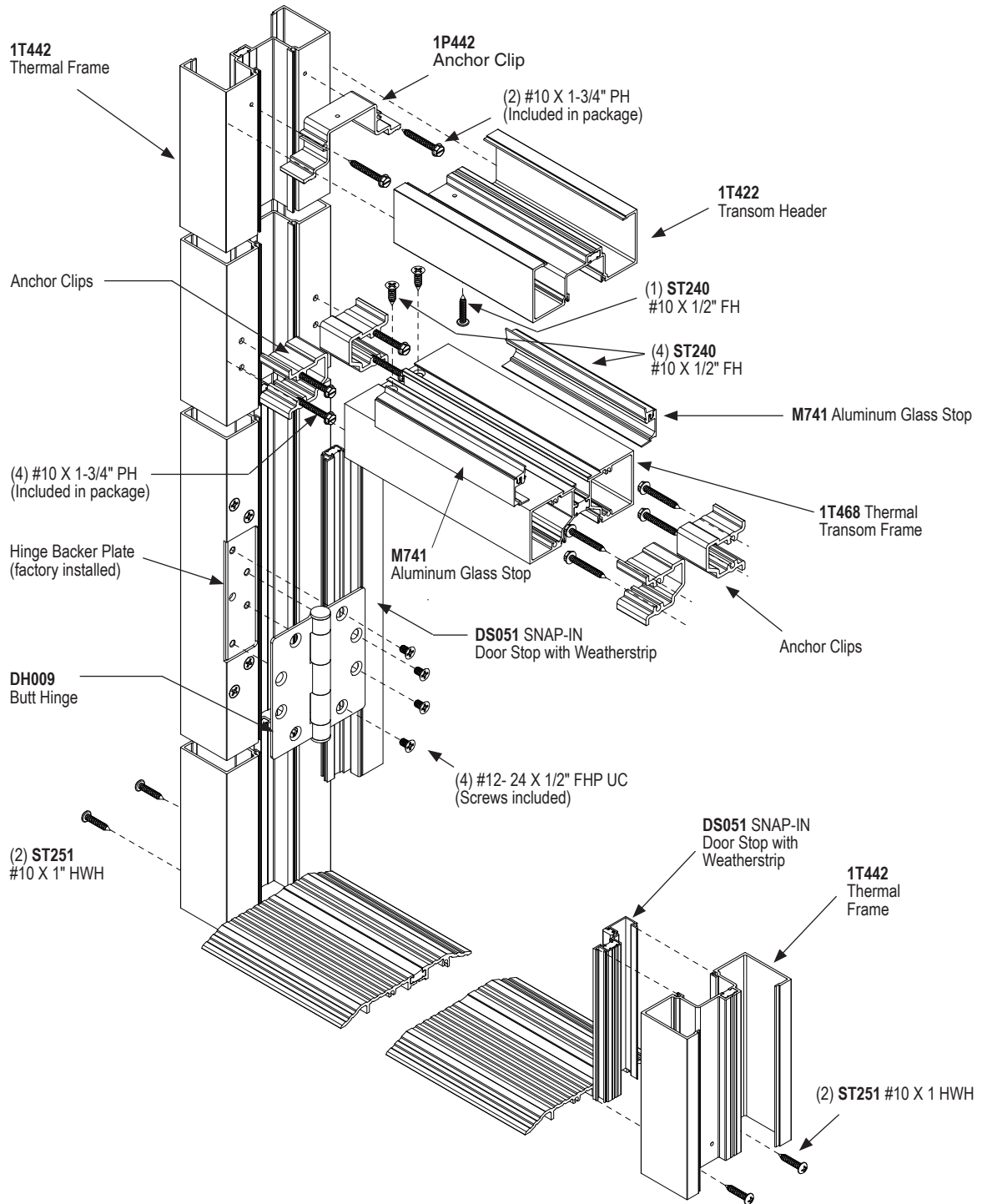

## ASSEMBLY INSTRUCTIONS:

1. Verify opening size. Allow for 1/4" (6.4) shim and caulk space at sides, and 1/2" (12.7) space at top of frame. (When using optional **AF100** sill flashing, allow 1/4" (6.4) shim space at top of frame).
2. If required, cut off top of vertical jambs to adjust frame to desired height.
3. Cut templates from inside frame boxes. Align edge of template with top of vertical and drill holes for head clips.
4. Attach anchor clips for head, door header, and threshold to jambs with provided screws
5. Butter contact surface of anchor clips with sealant. **(See DETAIL A).**
6. Assemble head and door header to jambs.
7. Install hinges to door jamb(s).

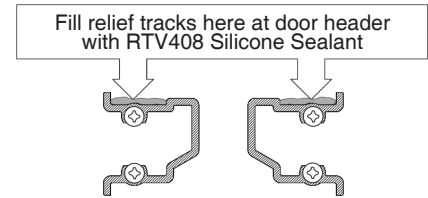

**DETAIL A**

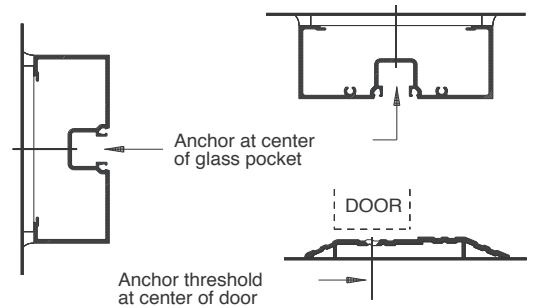

**DETAIL B**

## INSTALLATION INSTRUCTIONS:

1. Set frame into opening plumb and square.
2. Drill holes for #12 installation screws starting 6" (152) from corners and not more than 36" (914) O.C.
3. Secure jambs and head to opening and threshold to floor with #12 screws. **(See DETAIL B).**
4. Snap door stop with weatherstrip into jambs and door header. Jamb stops run through.
5. Place setting blocks in door header at quarter or eighth points as required, and glaze transom. Glazing sash is required vertically at Series 451 transom.
6. Install glass stops with glazing gaskets on both sides of glass.
7. Roll-in glazing gaskets for jambs and header.

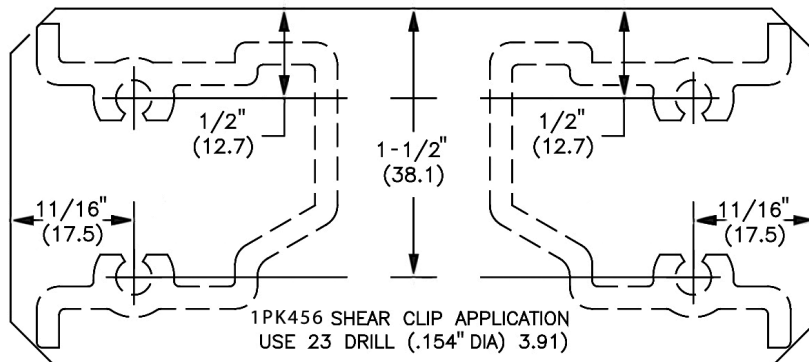
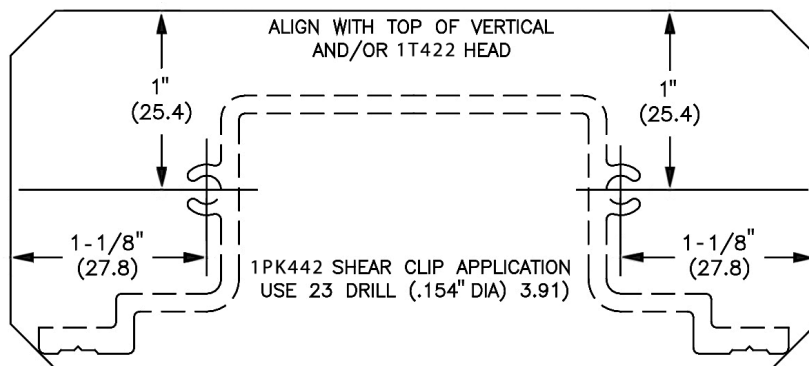

**NOTE: Do not cut templates from this manual. Templates are supplied inside frame boxes.**

# GLASS SIZE FORMULA AT TRANSOM

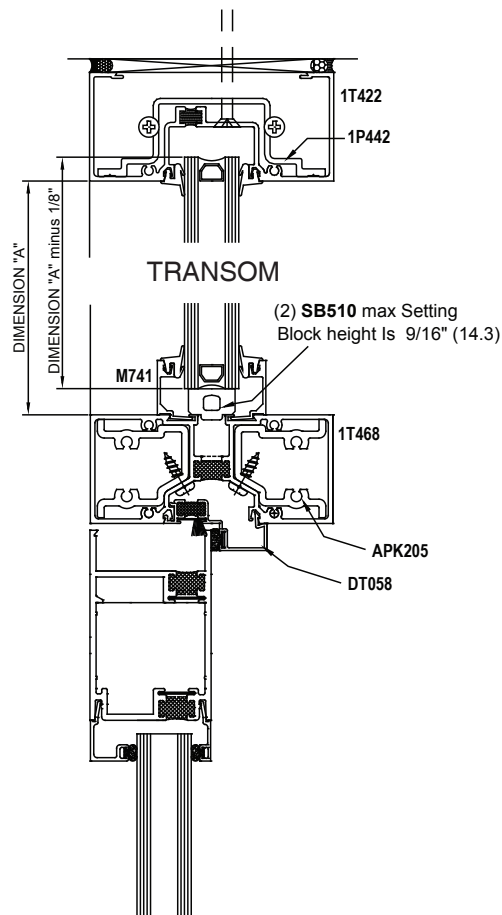

Offset Surface Closer

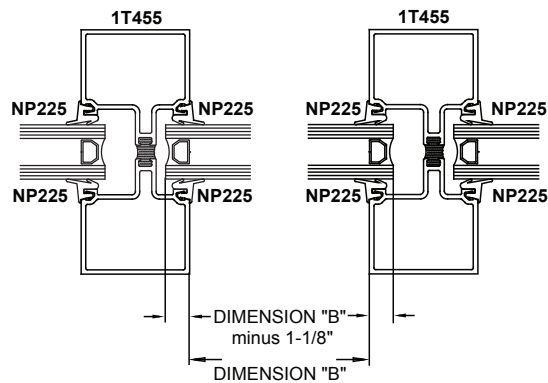

Door Frame Sidelites

# FRAME UNIT FOR OFFSET PIVOTED DOOR WITH SURFACE CLOSER

## SERIES IT455 FRAME

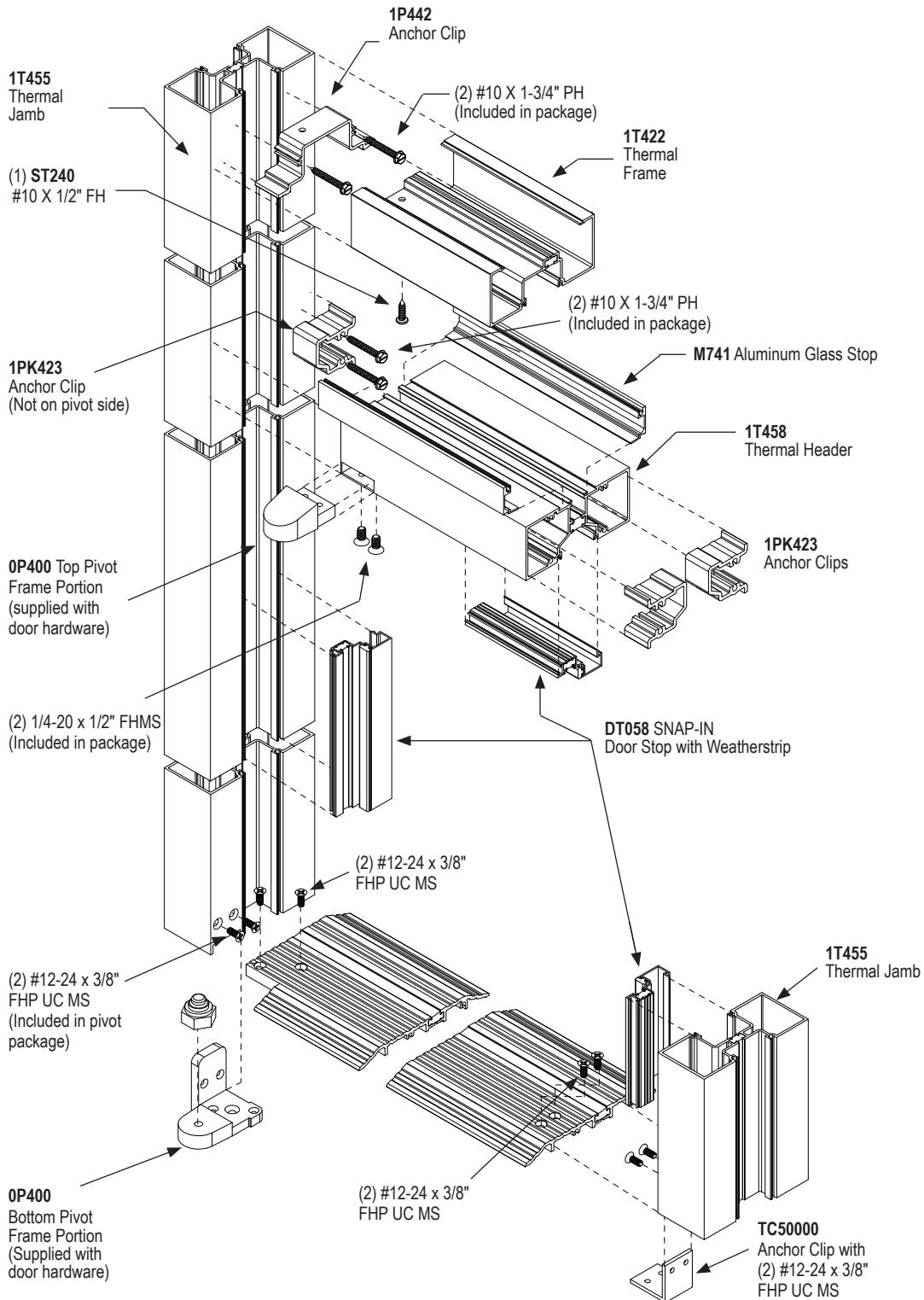

**ASSEMBLY INSTRUCTIONS:**

1. Verify opening size. Allow for 1/4" (6.4) shim and caulk space at sides, and 1/2" (12.7) space at top of frame. (When using optional **AF100** sill flashing, allow 1/4" (6.4) shim space at top of frame).
2. If required, cut off top of vertical jambs to adjust frame to desired height.
3. Cut templates from inside frame boxes. Align edge of template with top of vertical and drill holes for head clips.
4. Attach anchor clips for head, door header, and threshold to jambs with provided screws.
5. Butter contact surface of anchor clips with sealant. (See **DETAIL A**). Assemble head and door header to jambs.
6. Install hinges to door jamb(s).

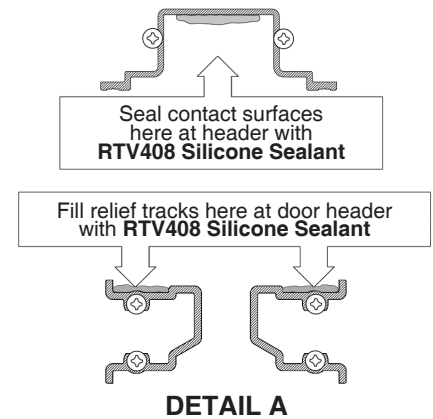

**INSTALLATION INSTRUCTIONS:**

1. Set frame into opening plumb and square.
2. Drill holes for #12 installation screws starting 6" (152) from corners and not more than 36" (914) O.C.
3. Secure jambs and head to opening and threshold to floor with #12 screws. (See **DETAIL B**).
4. Snap door stop with weatherstrip into jambs and door header. Jamb stops run through.
5. Place setting blocks in door header at quarter or eighth points as required, and glaze transom. Glazing sash is required vertically at Series 451 transom.
6. Install glass stops with glazing gaskets on both sides of glass.
7. Roll-in glazing gaskets for jambs and header.

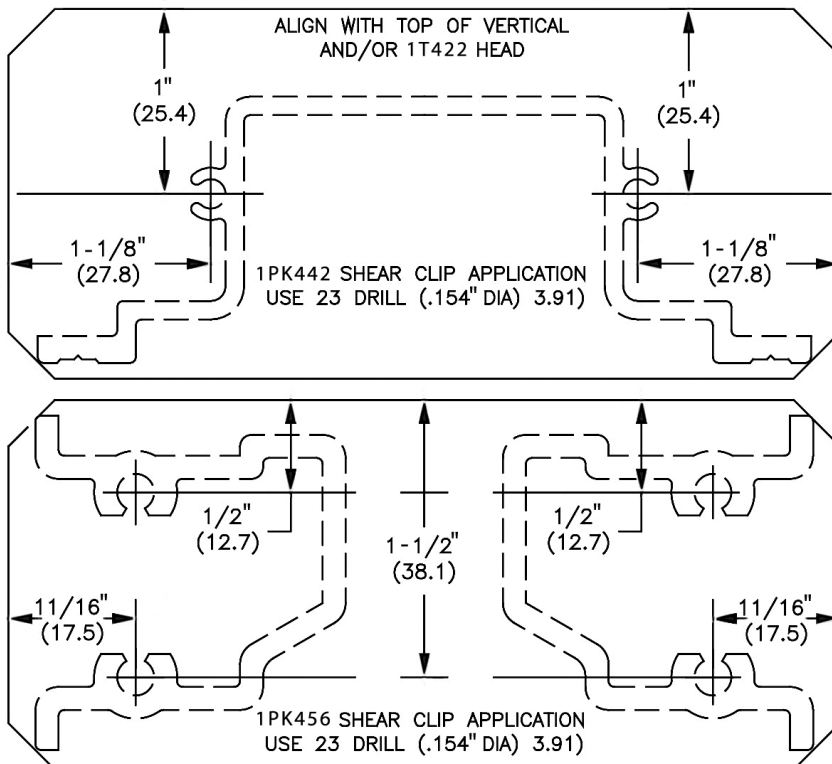
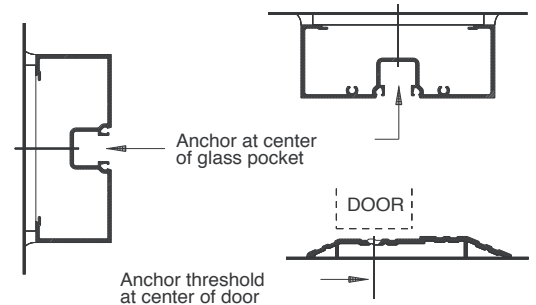

**NOTE: Do not cut templates from this manual. Templates are supplied inside frame boxes.**



# SUB - FRAME UNIT FOR OFFSET PIVOTED DOOR WITH SURFACE CLOSER

## TT461 THERMAL FRAME

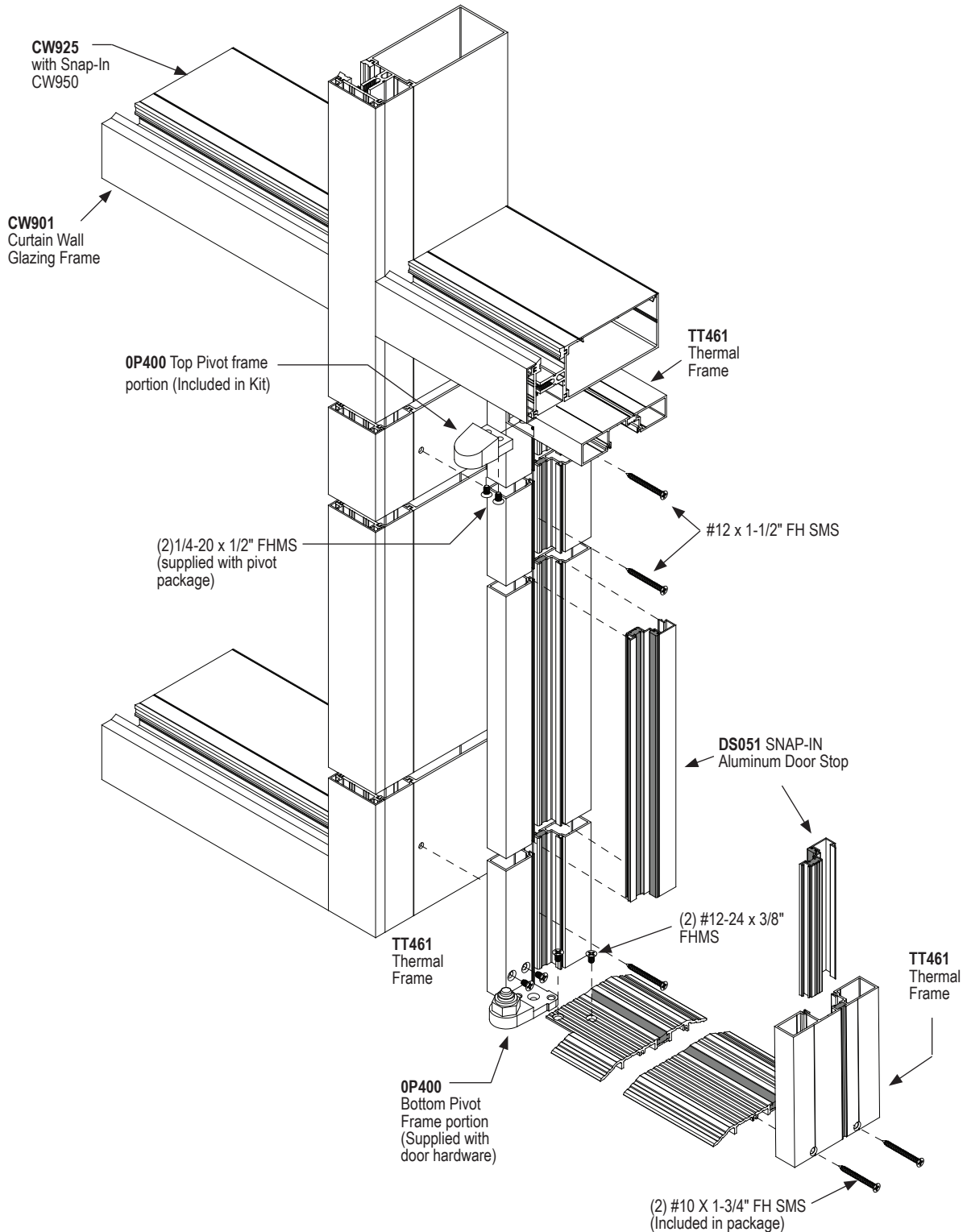

# OFFSET PIVOTED DOOR AND FRAME PREP

## HEADER

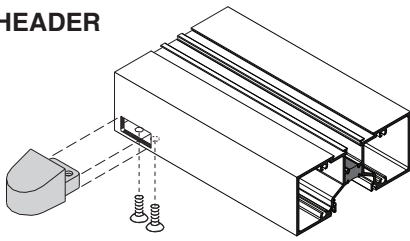

OR

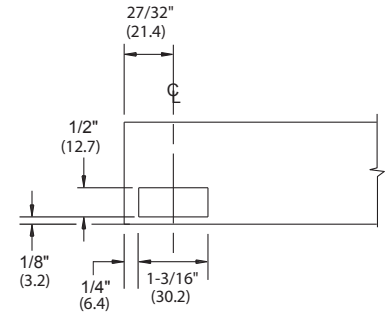
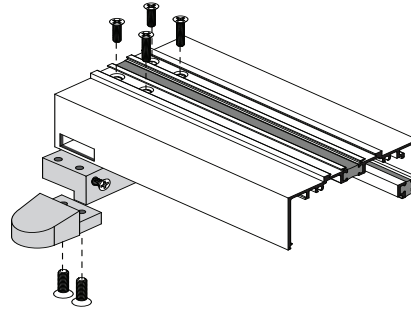

## HINGE JAMB

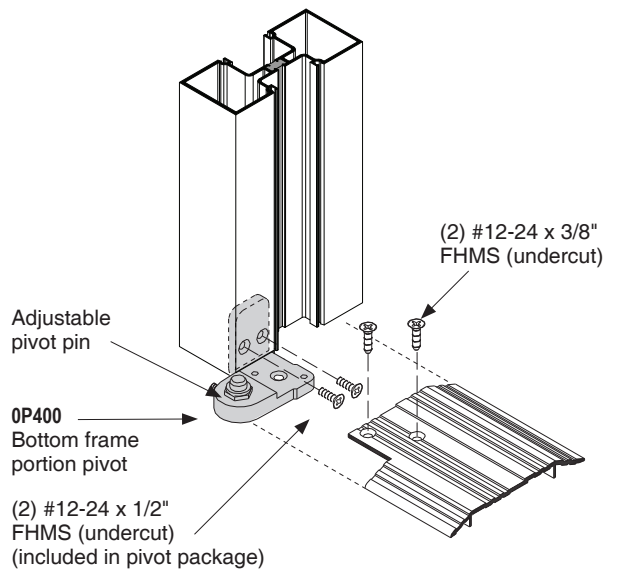
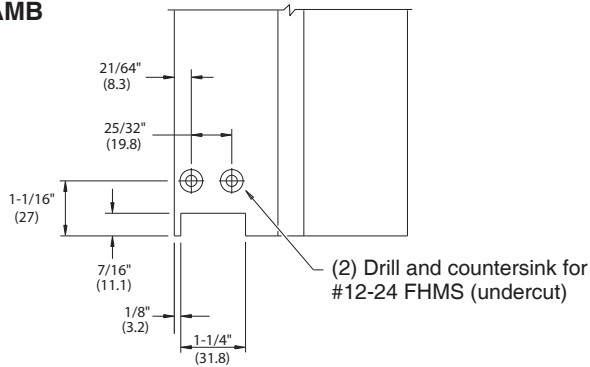

(2) Drill and countersink for #12-24 FHMS (undercut)

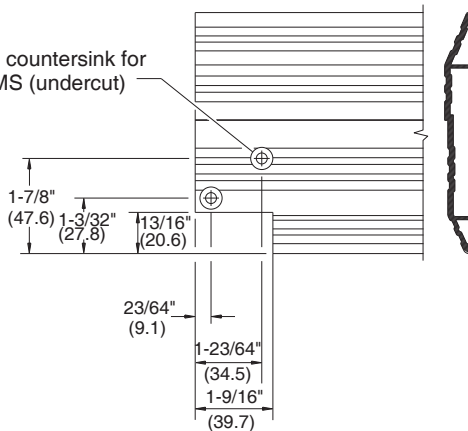

## DOOR

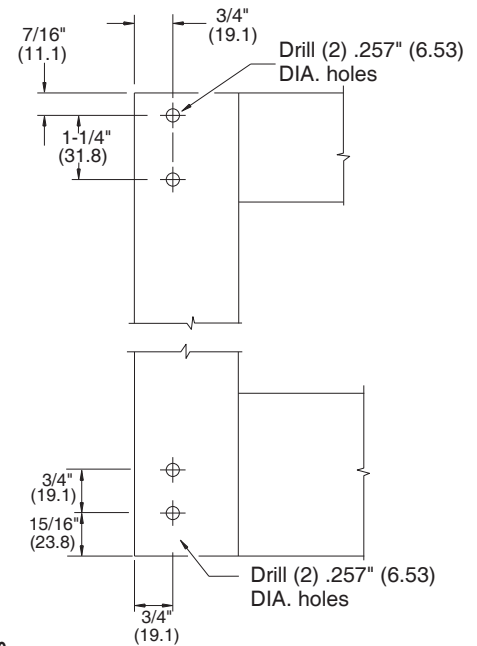
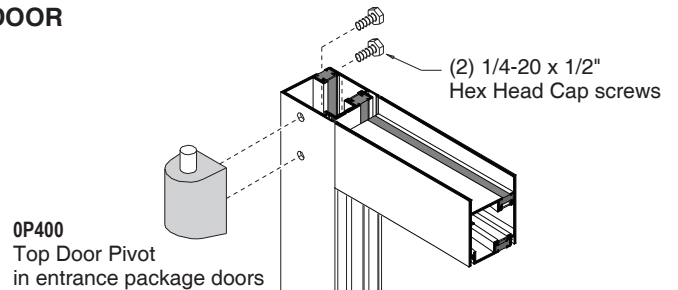

OP400 Bottom Door Pivot installed in door entrance package

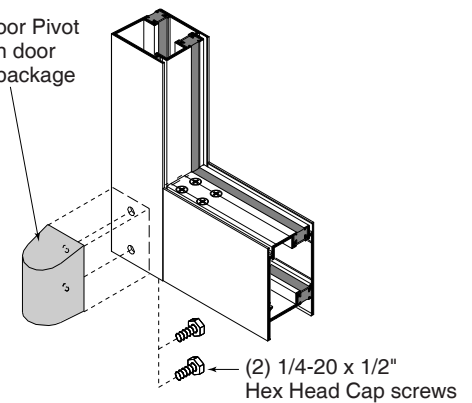

# PANIC DOORS WITH JACKSON 1285 CVR PANIC DEVICE

**NOTE:** CVR Panics available on 700T and 750T Series only.

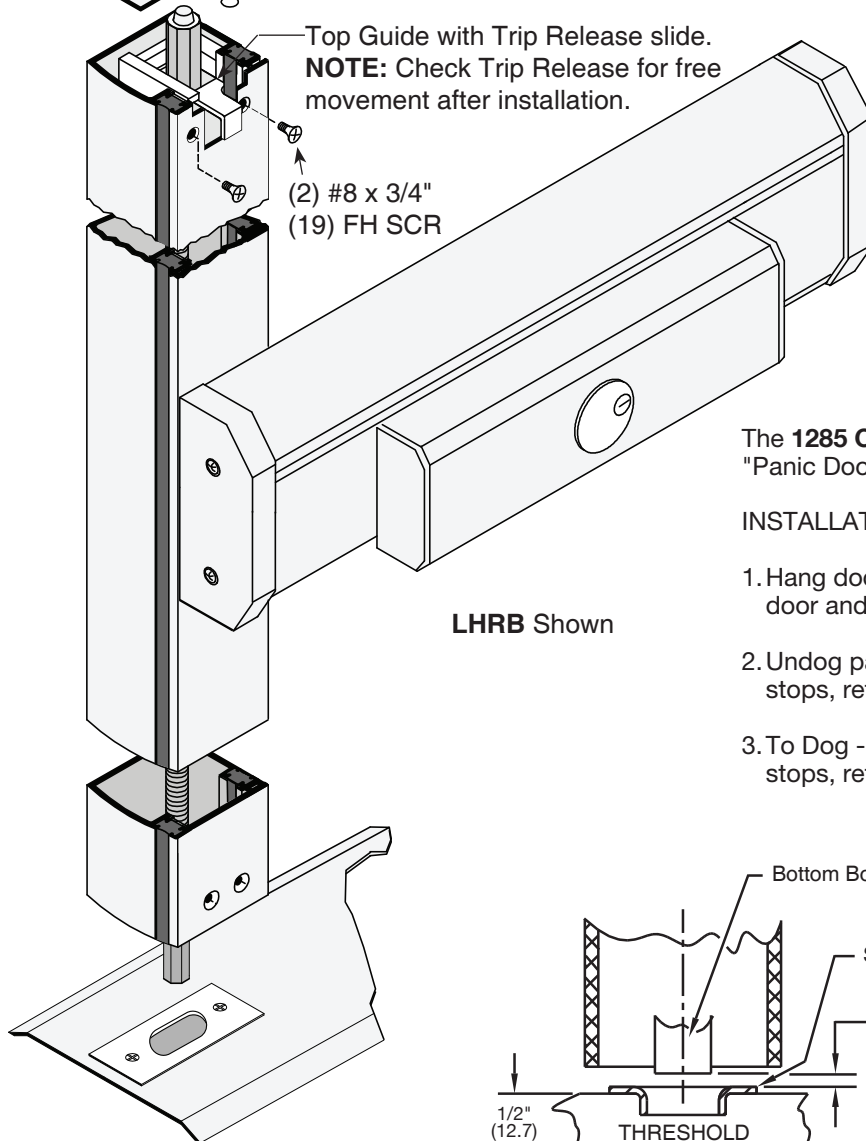
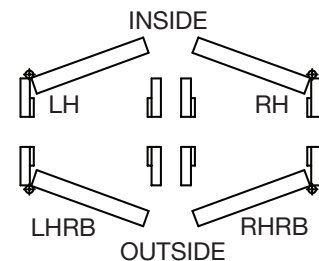
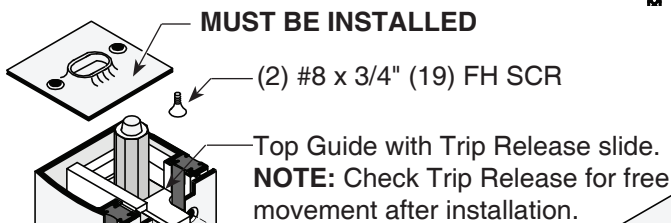
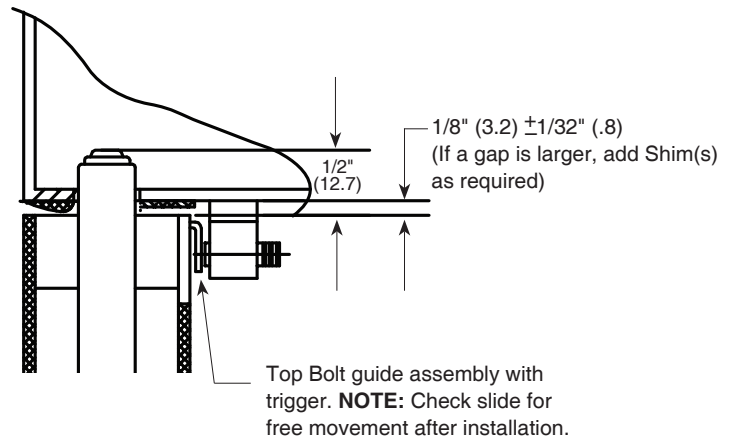
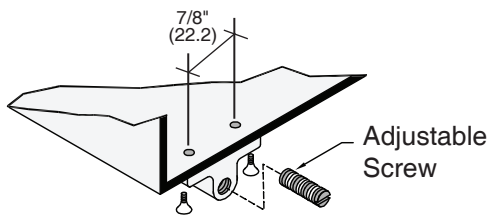

The **1285 CVR** Panic Device is factory installed in "Panic Doors"

**INSTALLATION PROCEDURE:**

1. Hang door, as required. The clearance between top of door and bottom of header **MUST NOT EXCEED 1/8" (3.2)**.
2. Undog panic. To Undog - insert key and turn CW until it stops, return key to original position than remove.
3. To Dog - Depress bar, insert key and turn CCW until it stops, return key to original position then remove.

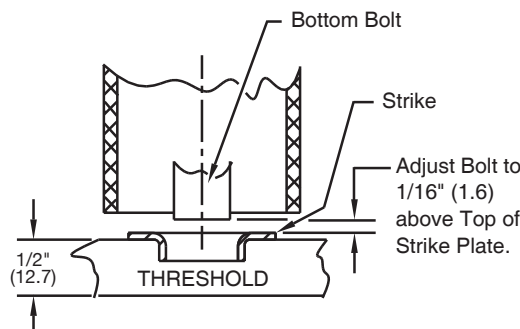

## PANIC DOORS WITH MODEL JACKSON 1295C RIM PANIC

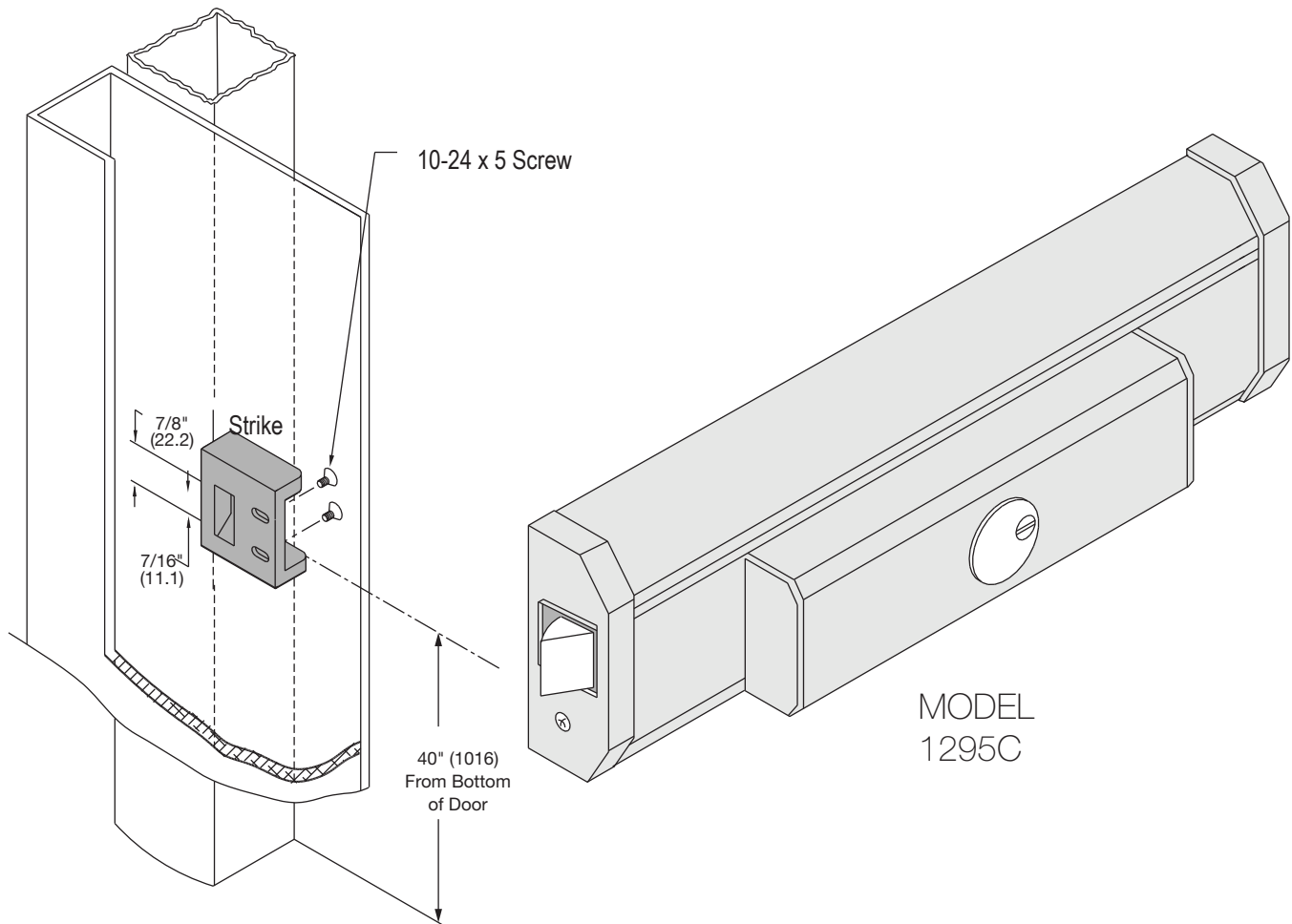

The **Model 1295C** Panic Device is factory installed in "Panic Doors"

### INSTALLATION PROCEDURE:

1. To install strike locate 10-24 taps on active stile (2 places).
2. Mount and secure strike. (Ref. DETAIL S).
3. Check operation of all parts including cylinder if being used to assure proper operation.

### Dogging Instructions:

To Dog - Depress bar, insert Key and turn CCW until it stops, return key to original position then remove.

To Undog - Insert key and turn CW until it stops, return key to original position then remove.

# DOOR GLAZING INSTRUCTIONS

1. Door may be glazed either Installed or Laid horizontal. Doors are more easily glazed in horizontal position. If glazing horizontally, leveling screw adjustments occur after hanging door.
2. Raise adjustable leveling screw to maximum retracted position.
3. Install glass stops, with glazing gaskets on one side of door only. If using square stops, install vertical stops first. If using beveled stops, install horizontal stops first.
4. Center glass in opening resting on setting blocks.
5. Snap-in remaining glass stops.
6. Turn leveling screw as required to maintain a uniform clearance between door top rail and header.
7. On pair of doors with astragal adjust screws to keep proper meeting stiles clearance.
8. On all weatherstripped door stiles pull the string to release weatherstrip pile after doors are installed.

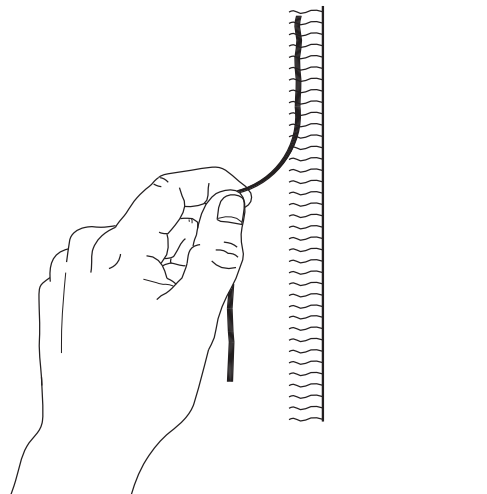
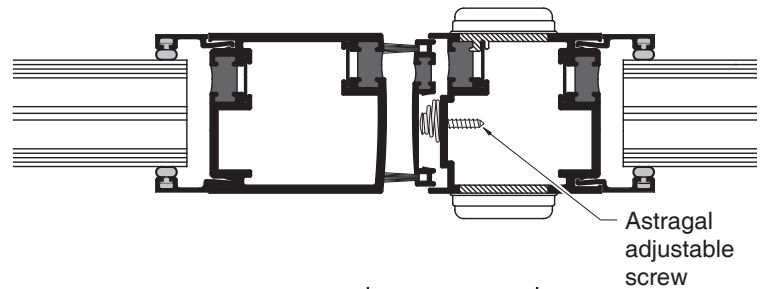
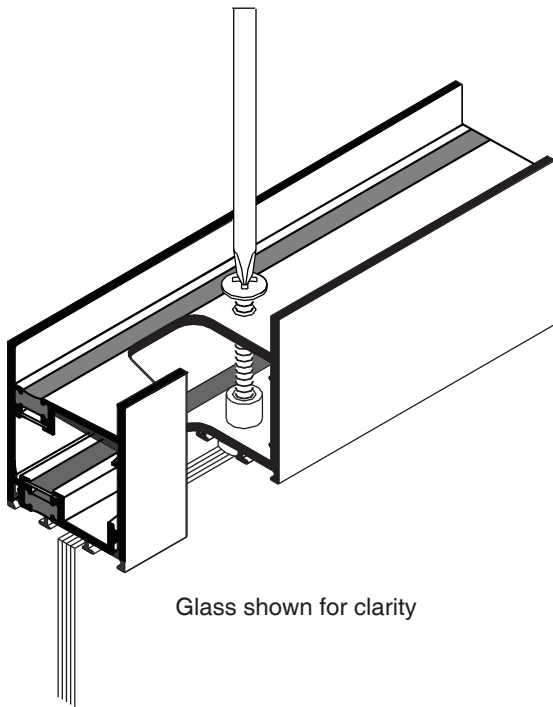
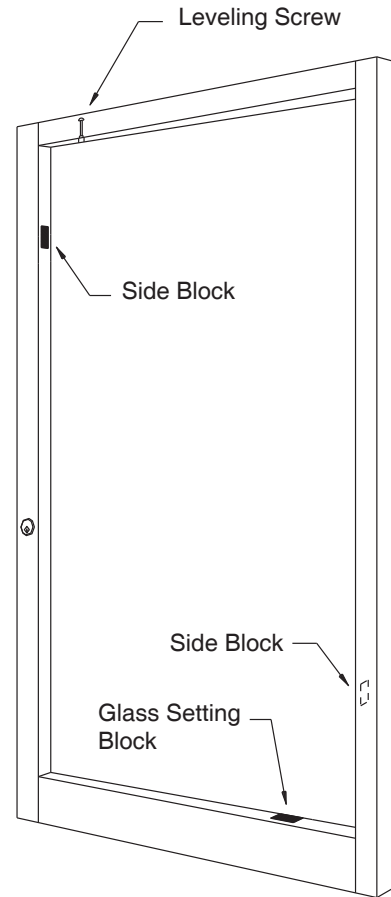

# BUTT HINGE (4-1/2" X 4")

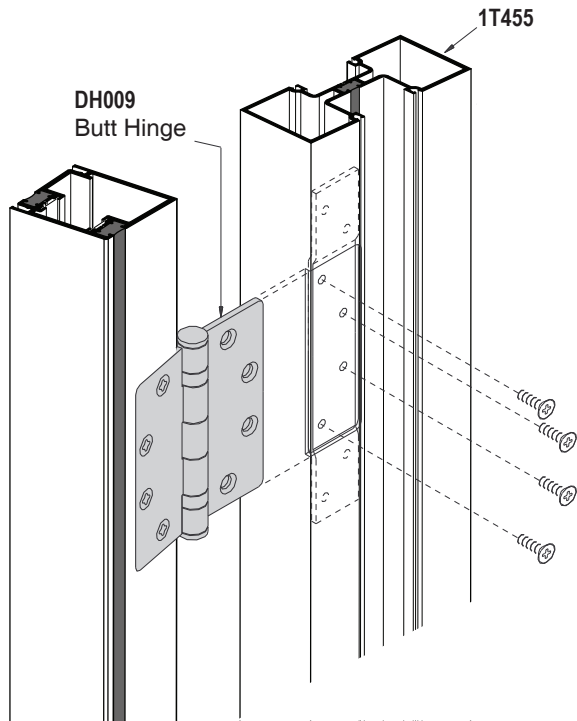

Prepare frame and door for hinges, as shown.

Back-up plates are factory installed in prepared doors and frames.

Install butt hinges in door. Set door in place and fasten hinges to frame.

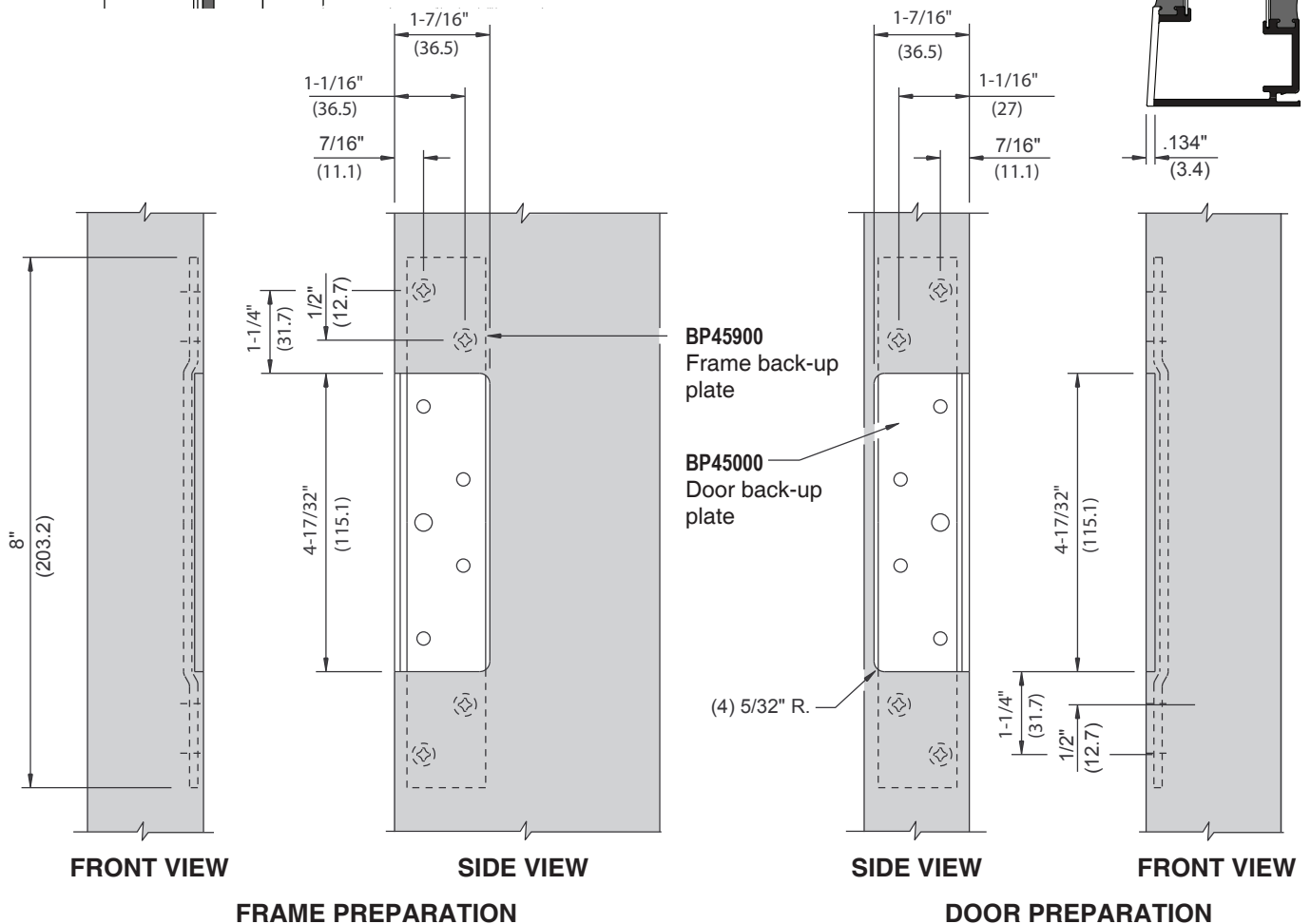



### HARDWARE - OFFSET HUNG DOOR TYPE "B" STANDARD PUSH/PULL FOR OFFSET DOORS

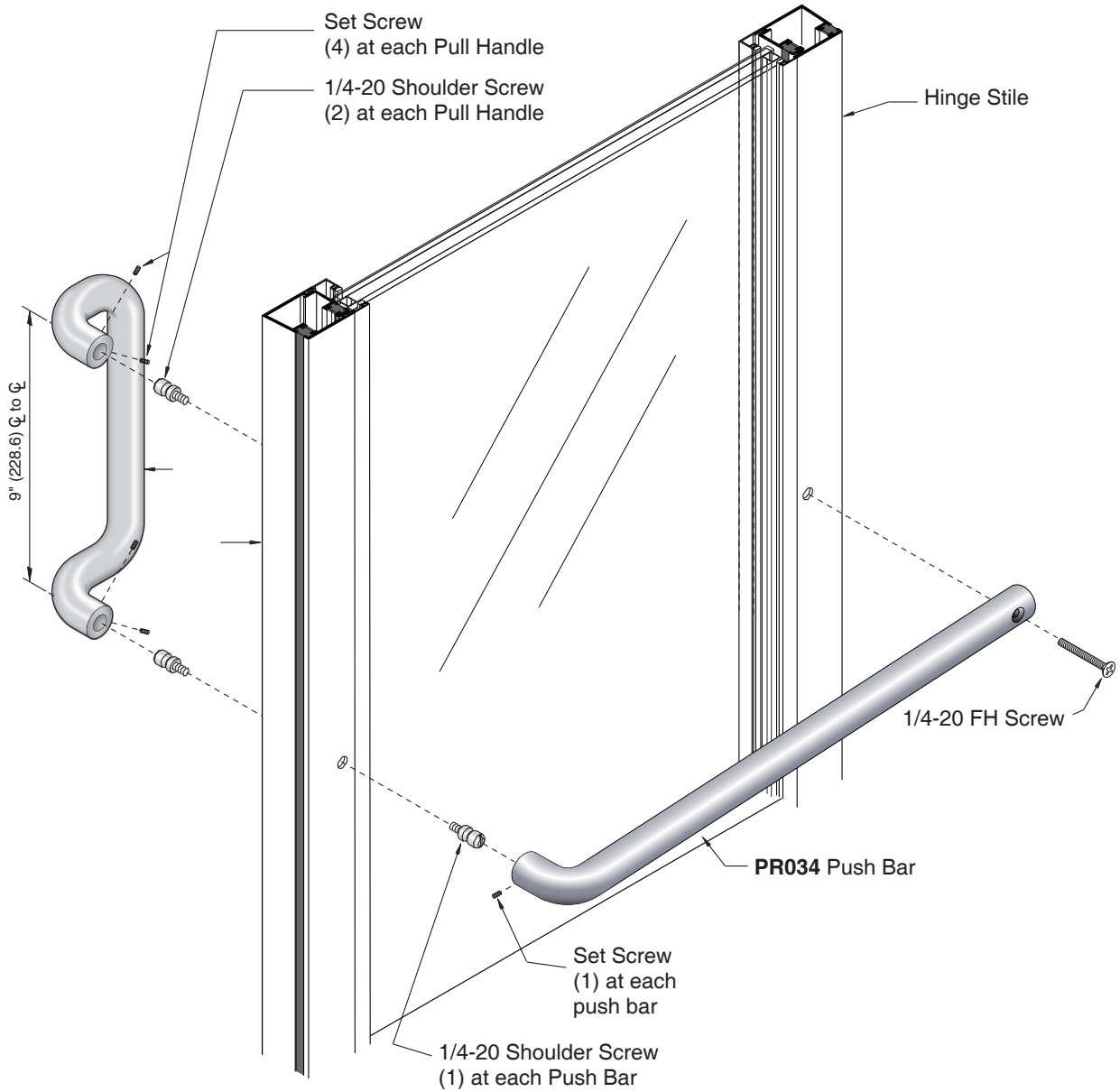



# GUIDE TO SEALANTS

**NOTE:** All sealants must be tooled to ensure proper adhesion.

## WATERPROOFING

- **33S ACETIC CURE SILICONE**

Sill to Subsill, End Dams, Screw Heads, and Threshold to Door Frame Sealing.

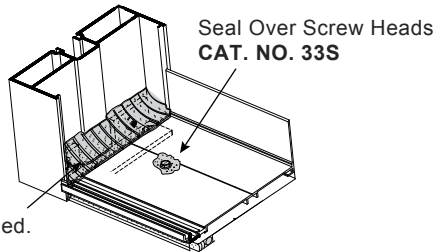

Fill with Sealant to Create a Water Shed.  
CAT. NO. 33S

**NOTE:** Not for use near insulating glass units with butyl sealant.

## EXPANSION

- **95C SILICONE BUILDING SEALANT**

Expansion Joints.

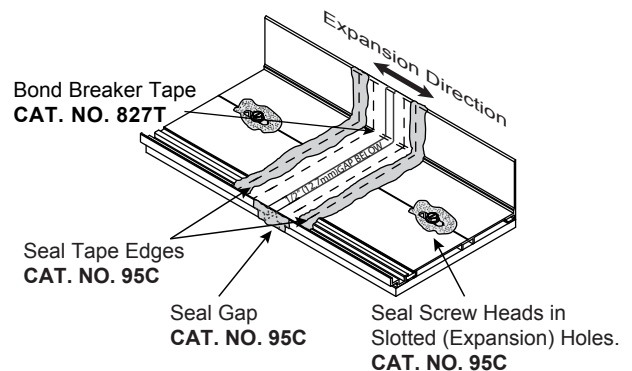

## JOINT ADHESIVE

- **RTV408 NEUTRAL CURE SILICONE**

Small Joints, End Joints and Buttered Surfaces, Water Diverters, End Dams, and Reglet Fills.

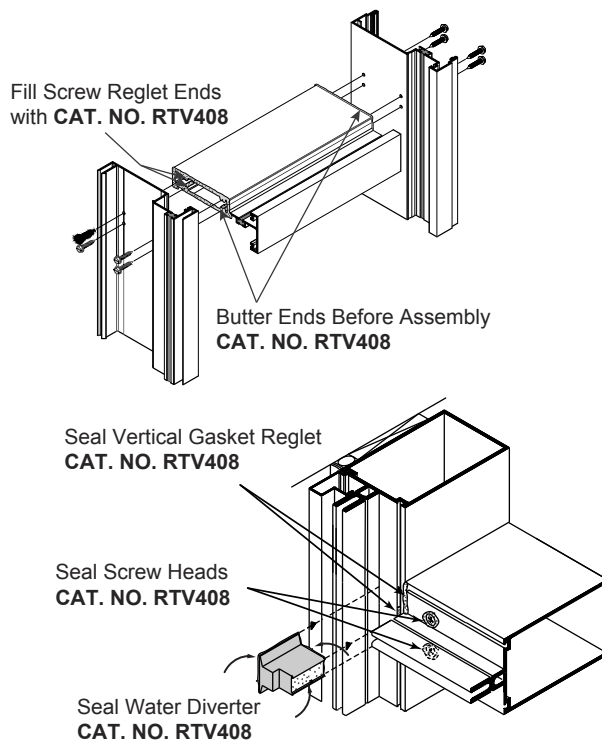

**NOTE:** I.G. butyl contact OK.

## PERIMETER

- **95C SILICONE BUILDING SEALANT (Preferred)**
- **M64 (SMOOTH) MODIFIED POLYURETHANE**
- **M66 (TEXTURED) MODIFIED POLYURETHANE**

Perimeter Seals, Expansion Joints, Sill and Threshold Beds, Concrete, Wood, and Steel Openings.

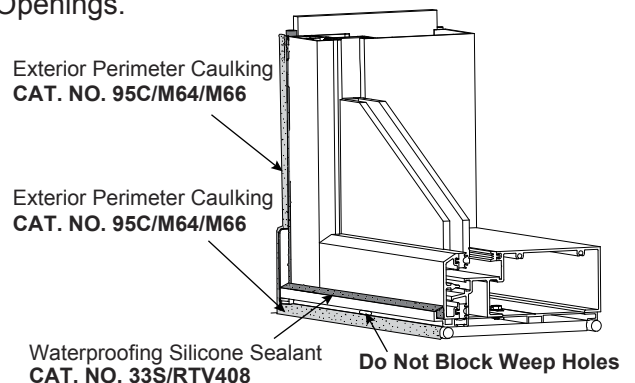

## STRUCTURAL

- **ALL STRUCTURAL SEALANTS REQUIRE TESTING AND APPROVAL.**

Glass-to-Glass or Glass-to-Metal