

# VE-1P

**VERTICAL EDGER  
VARIABLE SPEED  
OPERATION AND MAINTENANCE MANUAL  
(6/8/2013)**



**CRL GLASS MACHINERY  
5501 W. OGDEN AVE.  
CICERO IL 60804  
crlaurence.com  
(866) 583-1377**

## SECTION 1

### SAFETY

**FAILURE TO OBSERVE THE WARNING, CAUTIONS, AND INSTRUCTIONS LISTED IN THIS MANUAL AND ON THE DECALS ATTACHED TO THE VERTICAL EDGER COULD CAUSE SERIOUS INJURY TO PERSONNEL OR DAMAGE TO EQUIPMENT.**

#### GENERAL SAFETY INFORMATION

##### Introduction

This manual contains installation instructions and operating and maintenance procedures for the VE-1P Vertical Edger. The edger must be operated and maintained at all times in accordance with the instructions and procedures contained in this manual and on the decals attached to the edger. Only qualified personnel thoroughly familiar with the operating and maintenance should operate and maintain this equipment.

##### Safe Operating Considerations

Safety must be observed through all facets of operation and maintenance. Proper tools and operating procedures must be used at all times to prevent accidents, which could cause injury to personnel or damage to equipment. Safe reliable operation and long service life are dependent upon three important considerations:

- 1) Care exercised during installation.
- 2) Quality and frequency of inspection and maintenance.
- 3) Common sense approach to operation.

#### NOTES, CAUTIONS, AND WARNINGS

##### 1) Notes

### **NOTE**

***The notes contained throughout this manual provide additional information to carry out the operating and maintenance procedures. Any particular note is listed just prior to the procedural step to which it applies. This is an example of a NOTE format.***

**SECTION 1 (continued)****2) Cautions****CAUTION!**

**The cautions in this manual contain instructions and information concerning operation and maintenance procedures that, if not followed, could cause damage to equipment, parts and facilities. Like notes, cautions are listed just prior to the steps to which they apply. This is an example of a CAUTION format.**

**3) Warnings****WARNING!**

**The warnings in this manual contain instructions and information concerning operation and maintenance procedures that, if not followed, could cause injury to personnel. Warnings also are listed just prior to the steps to which they apply. This is an example of a WARNING format.**

**GENERAL PRECAUTIONS**

The precautions listed here are general in nature. Failure to observe and follow them could result in personal injury or damage to property. These general precautions are not all inclusive. Specific cautions and warnings are listed throughout this manual, and additional ones may occur that are peculiar to a particular operation or industry. In addition, employers are subject to the Federal Occupational Safety and Health Act (OSHA) of 1970, as amended, which requires that an employer keep abreast of the myriad regulations which will continue to be issued under its authority.

**SECTION 1 (continued)**

- 1) **Always** operate and maintain the edger in accordance with the instructions and procedures in this manual.
- 2) **Do not** exceed the capacity of the edger.
- 3) **Do not** open inspection doors while unit is in operation except in special circumstances which are addressed later in this manual.
- 4) **Never** work on the edger and related components unless electrical power and motor drive have been locked out and tagged.
- 5) **Do not** use edger for any purpose for which it was not designed. It is to be used solely to edge glass within the specification limits listed in this manual.
- 6) **Do not** poke or prod into the openings of the edger with a bar or stick.
- 7) **Always** have a clear view of the loading and unloading points and all safety devices of the edger.
- 8) **Always** keep area around edger, drive, and control station free of debris and obstacles.
- 9) **Never** operate edger without guards and all safety devices in position and functioning.
- 10) **Always** allow edger to stop naturally. **Do not** attempt to artificially brake or slow the motion of the edger.
- 11) **Always** wear safety glasses, proper gloves, and other necessary safety equipment while operating and maintaining the edger. When in doubt, consult with shop safety representative.

## SECTION 2

### DESCRIPTION

The VE-1P Vertical Edger Manual (herein referred to as "the edger") was designed to fill the need for a compact production machine to edge the most common range of glass thicknesses and sizes. The edger is ruggedly constructed, easy to operate and maintain, and produces quality edges. The edger consists of a frame with grinding (polishing) compartment, grinding (polishing) wheel and drive motor, conveyor system, glass support frame, coolant tank and pump.

The edger uses one diamond grinding wheel seven inches in diameter. For a higher luster finish after diamond grinding, a special polishing wheel rated for 3450 RPM can be interchanged with the diamond wheel. The edger will grind (and polish) edges of glass from a minimum thickness of single strength, .090" (2.28mm) to a maximum thickness of 1/2"(13mm). Wheels can be supplied to provide a pencil, flat-seamed or any special edge desired. The wheel is driven by a motor equipped with height adjustment for setting wheel depth, front-to-back adjustment for centering the wheel on the glass, and angular adjustment to pitch the wheel with respect to glass travel.

While in operation, the wheel is cooled with a diamond wheel coolant that is recirculated by a coolant pump. The purpose of the coolant pump and coolant tank is to supply a constant flow of diamond wheel coolant free of large glass grinds to the grinding (or polishing) wheel while the edger is in operation. The immersion pump supplies the coolant to the wheel and is returned to the coolant tank where most of the ground glass residue settles outside of the round weir surrounding the pump. The overflow of coolant at the weir supplies the pump reservoir section of the tank for recirculation.

The conveyor system is driven by a DC gearmotor and gears that drive the conveyor belt. The conveyor belt grips the glass and holds it securely in position during the grinding (polishing) operation. The rear belt and pressure rolls are designed so that the glass can be both gripped and released without cracking while being held in a straight path through the diamond wheel. The maximum speed in which the glass is conveyed through the edger is 66 inches per minute.

The glass support frame supports the glass as it is conveyed through the grinding (or polishing) operations. The frame can handle glass from a minimum size of 4 inches wide by 12 inches long (102 x 305mm) to a maximum of 72 inches wide by 72 inches long (1829 x 1829mm). The maximum glass weight is 250 pounds (113 kg) and the maximum glass thickness is 1/2 inch (13mm).

**SECTION 2 (continued)****SPECIFICATIONS****GLASS CAPACITY**

<b>THICKNESS</b>	<b>SINGLE STRENGTH (.090") TO 1/2" (2.28mm TO 13mm)</b>
<b>LENGTH</b>	<b>12" TO 72" MACHINE SUPPORTED (102mm TO 305mm)</b>
<b>HEIGHT</b>	<b>72 INCHES (1829mm) MAXIMUM</b>
<b>WEIGHT</b>	<b>250 POUNDS (113 kg) MAXIMUM</b>
<b>SPINDLE MOTOR</b>	<b>1-HP (.75 kw), 3600-RPM MOTOR WITH 7" (203mm) DIAMOND GRINDING WHEEL</b>

The wheel has adjustments for height to set the wheel depth, angularity for the glass thickness, an "In/Out" for wheel centering on the glass, and it can be profiled for pencil or flat-seamed edges.

<b>ELECTRICAL</b>	<b>1-PHASE, 60-HZ, 120 VOLT 1-PHASE, 50-60HZ, 220 VOLT</b>
<b>PLUMBING</b>	<b>NO DIRECT HOOKUP REQUIRED.</b>
<b>WEIGHT</b>	<b>APPROXIMATELY 750 POUNDS. (340kg)</b>

## SECTION 3

### RECEIVING

#### UNCRATING

Before the edger was crated for shipment, it underwent a successful test operation and was in proper working condition. Therefore, proper uncrating and inspection upon receiving is of the utmost importance to assure that the edger was received in exactly the same condition as it was when shipped from the factory. The edger and all ancillary components are shipped in one large crate.



### **WARNING!**

**The crate with the edger weighs approximately 800 lbs (362kg). Use adequate lifting devices to move the crate and avoid damage to the machine.**

#### INSPECTING THE CRATE

- 1) Crate damage could indicate mishandling during shipment and the edger could possibly be damaged. Inspecting the crate for exterior damage is an important part of the uncrating procedure.
- 2) Check all surfaces of the crate for gouges, tears or holes that could have been caused by the tines of a fork-lift or other lifting device.

**SECTION 3 (continued)**

- 3) Check for crushed corners and edges that could indicate the crate was dropped.
- 4) Check for broken support straps that position the edger and coolant tank on the mounting skid.

**REMOVING THE CRATE**

- 1) Remove top and side of crate. A claw hammer and prybar are suitable tools for this operation. Remove the protective plastic wrap covering the edger.
- 2) The edger is securely bolted and strapped to the main mounting skid. Carefully remove the bolts and strapping.

***NOTE***

***Small parts and accessories may be found wrapped and placed in the coolant tank, or boxed and attached to the mounting skid.***



**SECTION 3 (continued)**

- 3) Check the entire edger for damage, especially in the area of any crate damage as mentioned.
- 4) Use a proper lifting device and lifting slings to raise the machine and remove the mounting skid from beneath the edger. Position the machine in the work area. Remember that the main body of the machine weighs about 700 lbs. (317 kg.).

**NOTIFICATION**

Document all damage to the edger and components, if any, and notify the carrier and CRL Glass Machinery.

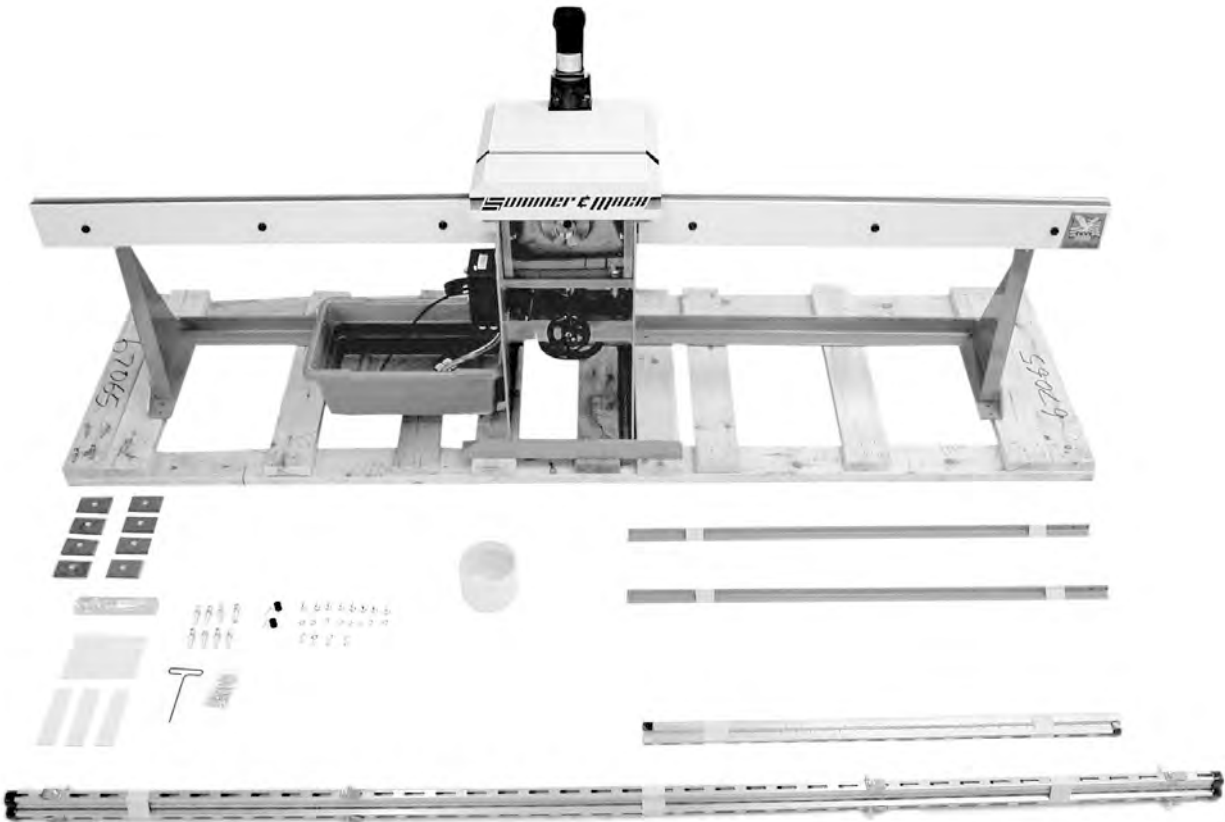

## SECTION 4

### INSTALLATION

#### FACILITIES REQUIREMENTS

##### SPACE

The required area to operate the edger is 11 feet wide, 6 feet deep and 7 feet high (3.3 x 1.8 x 2.1m). The floor area should be clean and free of oil, grease, and water.

##### PLUMBING

Although the edger requires no direct hookup, a water supply and drain should be easily accessible for filling, cleaning and draining the coolant tank and pump. Ideally, a floor drain should be located very close to the edger for run-off and cleaning.

##### ELECTRICAL REQUIREMENTS



**Make sure all electrical connections and service lines DO NOT contact water.**

A single phase, 60 Hz, 120 volt, FLA 13.5A power source with a grounded plug and cord (or single phase, 50/60 Hz, 220 volt, FLA 7.2A (male receptacle not supplied)) is required. All duplex outlets must be connected to earth ground. ***Do not*** use on a GFCI line. The power source must also have a safety disconnect switch for servicing the edger. Local electrical codes may require this switch. All wiring must meet local electrical codes.

#### ASSEMBLY INSTRUCTIONS

The edger and glass support frame are shipped fully assembled. The following will be all that is necessary to set-up the edger for production.

- 1) Set the machine on the provided leveling pads. Using the four inboard levelling screws, raise the machine 1/2" (13mm) off of the leveling pads. The four outboard levelling screws should not be touching the levelling pads. Remove the front guard and place a level lengthwise on the front aluminum plate; repeat the levelling procedure with the rear aluminum plate.

**SECTION 4 (continued)**

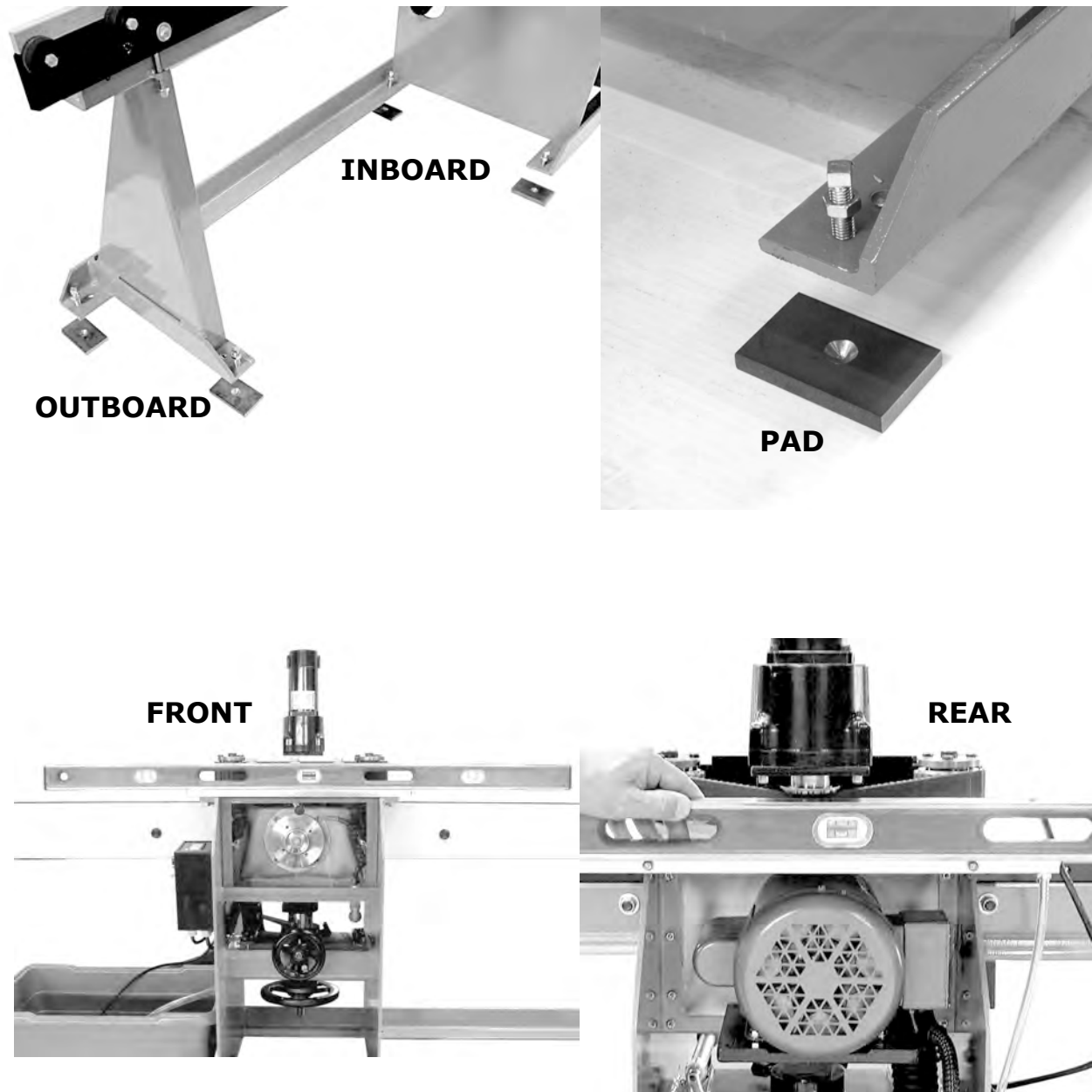

Using the four inboard levelling screws, level the edger from side to side. Once the edger is levelled, turn the four outboard screws until they just touch the levelling pads. Tighten all of the jam nuts on the levelling screws, being careful not to put the machine out of level.

**SECTION 4 (continued)**

- 2) Install the uprights as shown. Each upright is numbered and should be matched with the corresponding number on the ingoing and outgoing conveyor brackets.



The uprights bolt on using wedges to keep the bolts straight. Be sure to align the wedge under the lock washer and nut as shown below. Use a level to make sure the uprights are vertical before tightening the bolts.



**SECTION 4 (continued)**

- 3) Install the rack supports to the rails by sliding them on. The 4 short lower rails each require 2 supports. Add the plastic extension tubes and slide the supports so that they align with the holes in the vertical posts.



**SECTION 4 (continued)**

4) Fit the 4 lower rails to the vertical posts and secure them with washers and nuts. Secure the upper rails in the same manner.



5) Position the coolant tank on the side of the edger. Under the load conveyor, connect coolant hose and return hose from coolant pan on edger.

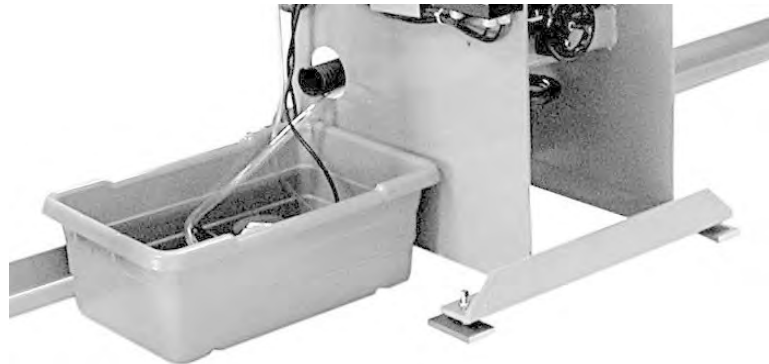

- 6) If there is not a wheel installed by the factory, see "MOUNTING DIAMOND/POLISHING WHEELS" in section 6.
- 7) Normally, mix 1 part of CRL diamond wheel coolant, CRL Cat. No. 2651005, or equivalent, to 100 parts water, or as recommended, in the coolant tank. For mixing purposes, approximate the capacity of the coolant tank at 8 gallons (30.2 ltrs). Use approximately 1.2oz (.043kg) of coolant.

***NOTE***

***Sometimes the coolant and water mixture may foam excessively, thus requiring sparing use of an anti-foaming agent (Cat. No. NS31F).***

## SECTION 4 (continued)

### TEST OPERATION AND WHEEL ADJUSTMENT

#### COOLANT PUMP

Turn the "CONVEYOR" power switch on and observe the coolant flow to the grinding wheel. Confirm that the nozzles are spraying at the point where the wheel touches the glass and returns into the tank.



#### ADJUSTMENT OF GRINDING (POLISHING) WHEEL

**WARNING!**

**When the edger is used for a polishing operation, it is mandatory to use a special polishing wheel designed to operate at 3600 RPM or faster. CRL CAT. NO. 39666000 or equivalent is recommended.**

Three adjustments must be made on the grinding (polishing) wheel prior to starting. One adjustment is for pivoting the wheel to the glass travel, the second is for the vertical height that controls the amount of glass being ground off, and the third is to locate the center of the wheel on the glass. The wheel is pivoted to allow the use of a wide profile wheel on a thinner piece of glass

**SECTION 4 (continued)**

The following table gives some typical angles to position the wheel. Each example mentioned will dictate actual angles. All wheels are different and resulting edge profiles are a matter of user preference.

<b>WHEEL PROFILE</b>	<b>GLASS THICKNESS</b>				
	<b>1/2" (13mm)</b>	<b>3/8" (9.5mm)</b>	<b>1/4" (6.3mm)</b>	<b>3/16" (4.7mm)</b>	<b>1/8" (3.2mm)</b>
<b>1/2" F&amp;S (13mm) 1/2" PE</b>	<b>0°</b>	<b>4° - 8°</b>	<b>8° - 15°</b>	<b>NR</b>	<b>NR</b>
<b>3/8" F&amp;S (9.5mm) 3/8" PE</b>	<b>NR</b>	<b>0°</b>	<b>4° - 8°</b>	<b>6° - 10°</b>	<b>8° - 15°</b>
<b>1/4" F&amp;S (6.3mm) 1/4" PE</b>	<b>NR</b>	<b>NR</b>	<b>0°</b>	<b>4° - 8°</b>	<b>6° - 10°</b>
	<b>0°</b>	<b>0° - 5°</b>	<b>5° - 8°</b>	<b>8° - 11°</b>	<b>11° - 15°</b>
	<b>NR</b>	<b>0°</b>	<b>0° - 5°</b>	<b>5° - 8°</b>	<b>8° - 11°</b>
	<b>NR</b>	<b>NR</b>	<b>0°</b>	<b>0° - 5°</b>	<b>5° - 8°</b>

F&S = Flat and Seam

PE = Pencil Edge

NR = Not Recommended

*Table*



**Make sure the spindle motor switch is off before adjusting wheel.**

- 1) Loosen the angle adjustment lever ("A") on the angle adjustment plate. Pivot the spindle motor manually to the desired angle by use of the angle index scale on the front of the adjustment plate. Tighten the screw securely.
- 2) Loosen the jam nut and spindle lock ("D") and turn the vertical adjustment handwheel ("C") counterclockwise until the grinding wheel is approximately 1/2" below the top of the grinding compartment.
- 3) Turn on the conveyor pump and spindle motor switch, and the conveyor "Forward" toggle switch. The grinding wheel is rotating counterclockwise when facing the front of the edger.

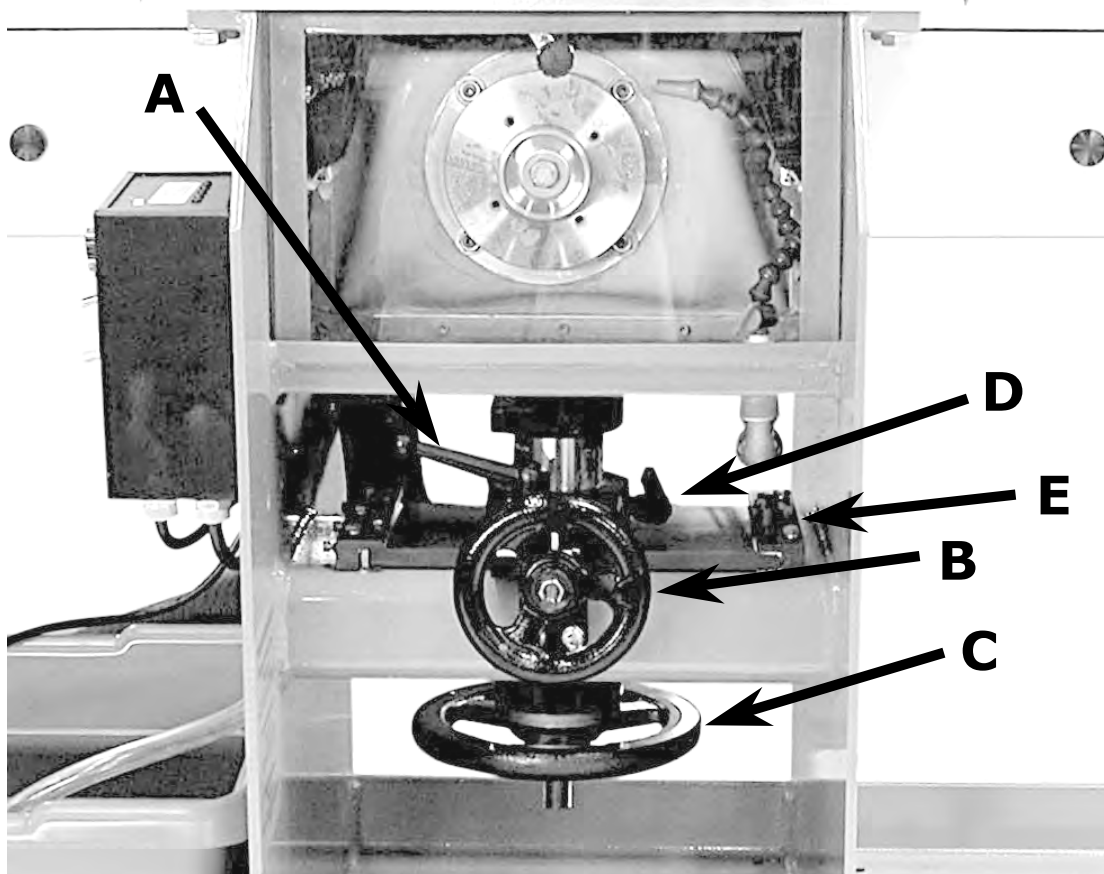

## SECTION 4 (continued)

**WARNING!**

**Before proceeding with the following steps, make certain that the conveyor is operating properly. See Section 4, "CONVEYOR", and perform all steps as outlined before any operation with glass.**

- 4) Insert a piece of glass of a thickness for the wheel size and feed it into the edger. Stop the conveyor the using the toggle switch when the glass is above the grinding wheel.
- 5) Loosen the jam nut and spindle lock ("D") and turn the vertical adjustment handwheel ("C") clockwise to raise the grinding (polishing) wheel until it just contacts the glass. Then turn the vertical adjustment handwheel 1/2 turn counterclockwise so that the wheel is no longer contacting the glass.

**SECTION 4 (continued)**

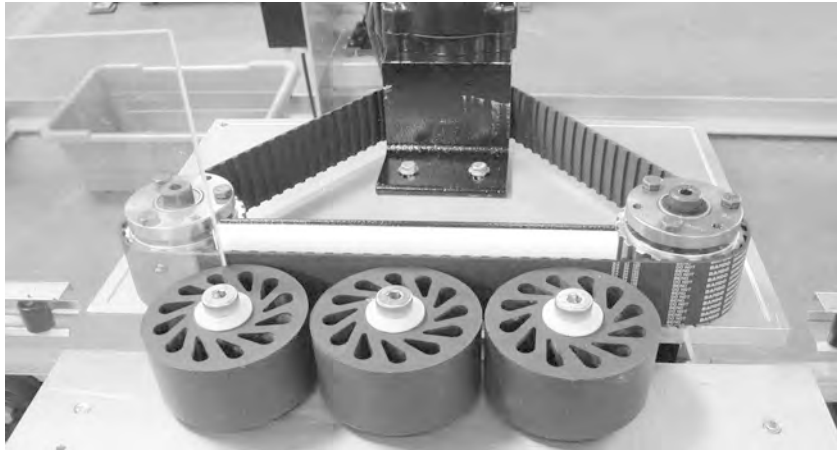

**GLASS ENTERING ROLLER SECTION**

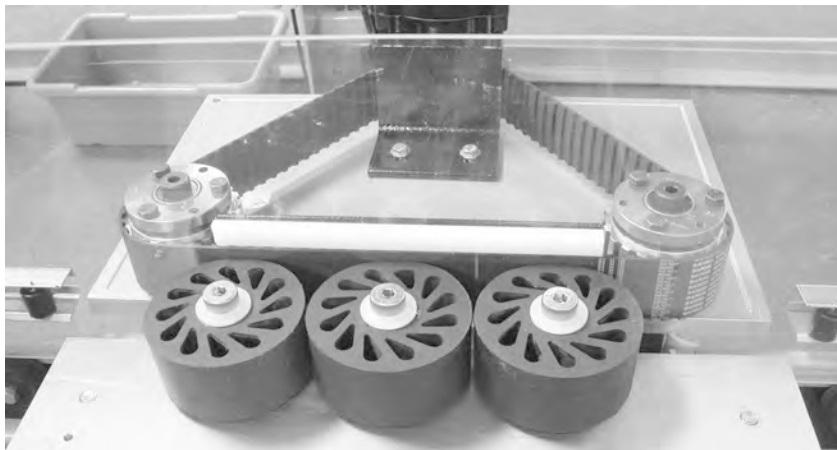

**GLASS BEING GROUND/POLISHED**

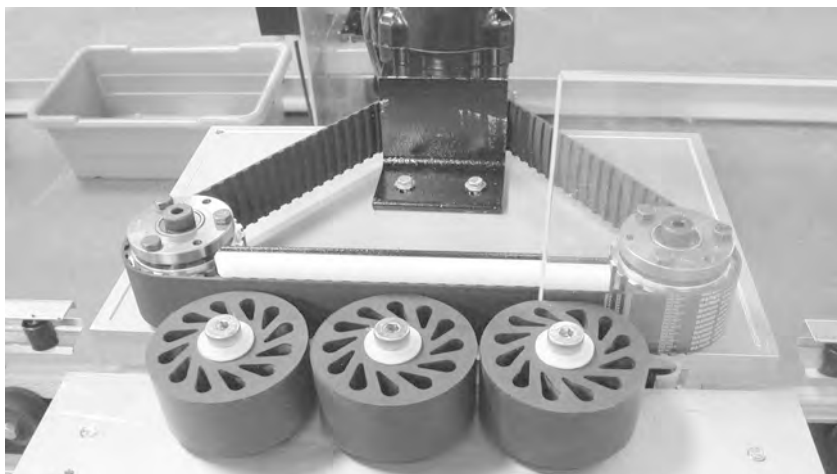

**GLASS EXITING ROLLER SECTION**

**SECTION 4 (continued)**

- 6) Reverse the conveyor and move the glass out of the edger.
- 7) Turn the vertical adjustment handwheel clockwise to adjust the height of the grinding wheel to grind off approximately 0.025" (.63mm) of glass. Each clockwise turn of the handwheel moves the spindle up 0.063" (1.6mm). Lock the adjustment handle in the position using the jam nut and tighten the spindle lock.
- 8) Run the test glass completely through the edger so that the edge is ground. Examine the ground edge to ensure that the glass is striking the wheel at the center of the groove.
- 9) If the glass is not striking the center of the groove, use the horizontal adjustment plate to center the wheel on the glass. To move this plate, loosen the gib lock ("E") and rotate the handwheel ("B") clockwise to move the wheel forward and counterclockwise to move the wheel back.
- 10) Recheck all screws and nuts for each adjustment and retighten if necessary.
- 11) Run the test glass completely through the edger. Make adjustments in wheel height and groove centering to produce a minimum amount of glass removal with the desired edge. At the same time, check the alignment of the "Infeed to Center Section to Outfeed". The glass should remain straight. It should not ride up or down during grinding. The amount of glass removed should be constant from end to end.
- 12) If the edger is to be used for polishing, position and adjust the polishing wheel so it makes contact with the glass (see "WARNING" at the beginning of this section) and repeat steps 4 through 10 to adjust the polishing wheel.

***NOTE***

***If a new polishing wheel is installed and is not dressed for thickness of glass and profile of edge, refer to Section 6 for dressing procedure.***

**SECTION 4 (continued)****CONVEYOR**

The coolant pump will not run unless the conveyor system is on.

- 1) Place the Forward/Off/Reverse toggle switch in the "FORWARD" position.
- 2) Verify that the back conveyor belt is moving counterclockwise (when facing the front of the edger).
- 3) Place the Forward/Off/Reverse toggle switch in the "REVERSE" position. Verify that the conveyor belt is moving clockwise as noted in Step 2.
- 4) Place the Forward/Off/Reverse toggle switch in the "FORWARD" position and turn off the grinding (polishing) wheel. By turning the conveyor speed adjuster on the D.C. control box, you can vary the glass feed rate from 0 to 66 inches/min. Specific requirements, such as a better polish, may require a slower feed rate. A chart below is showing approximate speeds.

**Conveyor Speed Setting vs. Actual Speed**

<b>Conveyor Controller Speed Setting</b>	<b>Actual Speed Feet per Minute - FPM (mm per minute)</b>	<b>Actual Speed Inches per Minute -IPM</b>
<b>100</b>	<b>5.5 (1676.4)</b>	<b>66.0</b>
<b>90</b>	<b>5.2 (1584.9)</b>	<b>62.4</b>
<b>80</b>	<b>4.6 (116.8)</b>	<b>55.2</b>
<b>70</b>	<b>4.0 (101.6)</b>	<b>48.0</b>
<b>60</b>	<b>3.6 (91.4)</b>	<b>43.2</b>
<b>50</b>	<b>2.8 (71.1)</b>	<b>33.6</b>
<b>40</b>	<b>2.2 (55.9)</b>	<b>26.4</b>
<b>30</b>	<b>1.16 (29.4)</b>	<b>13.9</b>
<b>20</b>	<b>1.0 (25)</b>	<b>12.0</b>
<b>10</b>	<b>0.42 (10.6)</b>	<b>5.0</b>

## SECTION 5

### OPERATING INSTRUCTIONS

#### **GRINDING INFORMATION**

It may be necessary to run the glass through the edger more than once. The number of "passes" through the edger for grinding a specific edge is dependent upon four factors:

- 1) Grit and type of the grinding wheel
- 2) Depth of grind
- 3) Smoothness of finished edge
- 4) Size of rough-cut flares

Multiple "passes" may also indicate that the diamond wheel may have loaded up with glass grinds, glazed over, or wore the diamond matrix below the surface of the bonding material. See the "Maintenance" section.

Grit of the diamond wheel is very important to the ease of grinding. The coarser the grit, the easier the wheel will edge. However, coarse grit wheels will leave rough edges with chips. Conversely, fine grit wheels make a smooth cut, and do not remove as much glass per pass.

The amount of glass that must be removed is another important consideration. For the longest wheel life, the smallest amount of glass possible should be removed utilizing more passes or a slower conveyor speed. The cut of the glass edge determines the amount of glass to be removed. If the cut edges are straight, without flares or protrusions, then the amount of glass to be removed is minimal. If the cut edges are jagged and uneven, a greater amount of glass will have to be removed.

The correct amount of passes, conveyor speed or depth of cut for the desired edge will have to be determined for each thickness of glass. Through experimentation, the combination that gives the desired results should be documented so that the procedure can be duplicated at a later date.

#### **OPERATION**

#### **ADJUSTMENTS**

- 1) Set the grinding (or polishing) wheel to the proper setting for the thickness of glass to be ground. (See "ADJUSTMENT OF GRINDING (POLISHING) WHEEL" in Section 4.)
- 2) Adjust height of wheel for desired depth of cut (see Section 4).

## SECTION 5 (continued)

### EDGER START-UP

- 1) Turn the spindle switch to "ON".
- 2) Place the conveyor and coolant pump toggle switch in the "ON" position. Note - the coolant is streaming directly on the wheel.
- 3) Make sure the conveyor drive toggle switch is in the "Forward" position.

## CAUTION!

**Do not run glass unless coolant is flowing to the wheel at the point where the wheel contacts the glass. If a diamond wheel is run dry, the heat generated may break the glass and damage the wheel. Never exceed glass capacity of the edger as listed in "SPECIFICATIONS" in Section 2.**

- 4) Load the glass onto the infeed rack (left side, when facing the front of the edger) and convey the glass by hand until it reaches the conveyor belt pad. The front pressure roll and rear conveyor will grip the glass and begin the normal operation.

### CONVEYOR ADJUSTMENT

To adjust the ingoing and outgoing conveyors, remove the guards and loosen the 3/8 hex head bolt located just above the adjusting screw. Loosen the jam nut and turn the adjusting screw to the desired position. ***Do not*** adjust the eccentrics near the spindle (grinding section). These are factory set. Once adjusted, repeat the procedure on the other conveyor.



**SECTION 5 (continued)**

Run a piece of glass at least 72 inches long and listen to the cut. If the sound becomes quieter toward the end of the cut, lower the ingoing conveyor (**1/2 turn of the adjustment screw**) and raise the outgoing conveyor (**1/2 turn of the adjustment screw**).

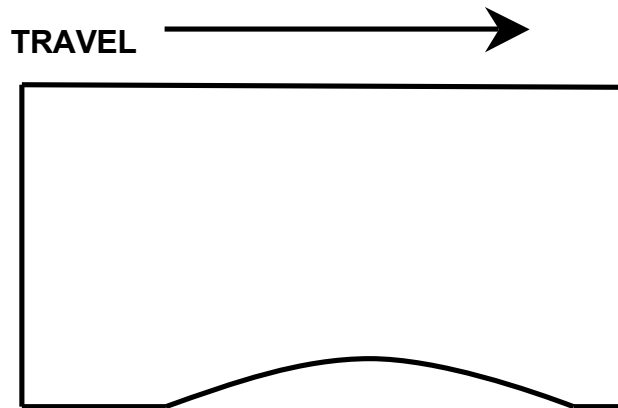

To change this condition, the ingoing conveyor adjustment must be raised 1/2 turn and the outgoing conveyor must be raised **1/2 turn**.

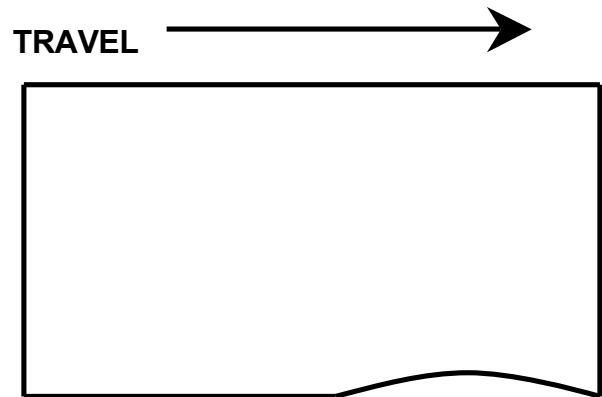

To change this condition, the outgoing conveyor adjustment must be lowered **1/8 turn** and the ingoing conveyor must not be adjusted.

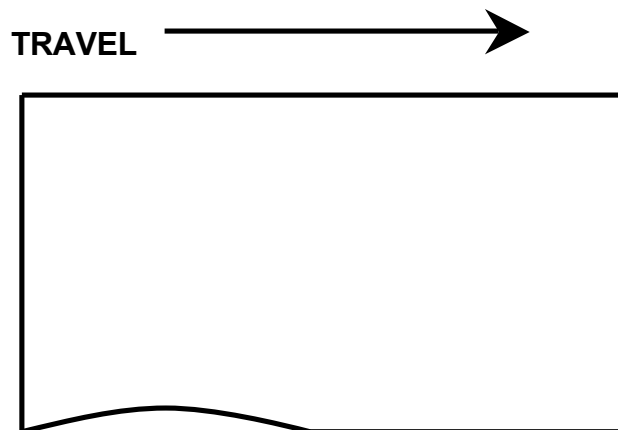

To change this condition, the ingoing conveyor adjustment must be lowered **1/8 turn** and the outgoing conveyor must not be adjusted.

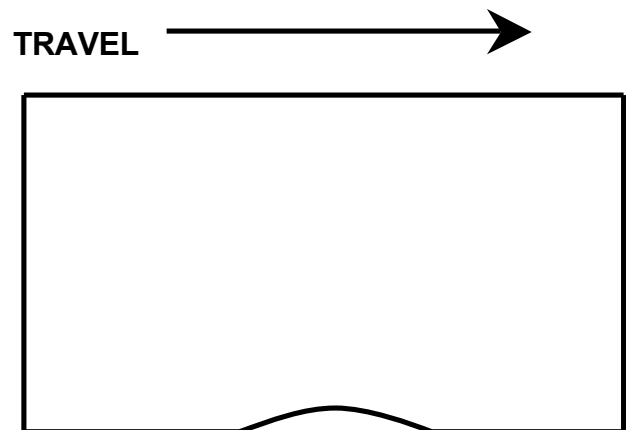

This will move to the left depending on the conveyor being adjusted. To eliminate this condition, adjust both conveyors up **1/8 turn**.

Refer back to STEP#5 in SECTION 4 (page 16) to reset depth of cut.

## SECTION 6

### MAINTENANCE INSTRUCTIONS

# WARNING!

**Disconnect the main power to the edger before performing any maintenance. Failure to do so could result in serious injury or death.**

#### SPINDLE MOTOR

To replace the spindle motor;

- 1) Shut off the main power to the edger and disconnect the wiring.
- 2) Remove the four screws and washers that attach the wheel to the motor spindle. Remove the spindle hub bolt. Remove the spindle hub using a suitable wheel puller. Remove motor slinger and rubber curtain assembly.
- 3) Remove the four hex head screws and washers that secure the motor to the base plate.
- 4) Install new motor by reversing this procedure.

#### COOLANT SYSTEM

To ensure optimum performance, this procedure must be done after 8 hours of operation;

- 1) Drain and clean the coolant tank and the pump (see ADDENDUM, PUMP MAINTENANCE, page 32).
- 2) Flush the lines and the coolant pan in the center section below the grinding (polishing) wheel.
- 3) After cleaning the tank, refill it with a mixture of 1 part of CRL Cat. No. 2651005 coolant, or equivalent and 100 parts of water, or as recommended. For mixing purposes, the approximate capacity of the coolant tank is 8 gallons (30 ltrs), leaving a 1" (13mm) head space. The coolant concentrate improves the finish of the grinding (& polishing) operation and inhibits rust formation on the parts of the edger.



**SECTION 6 (continued)****NOTE**

***If using a polishing wheel, some wheels do not polish very well with high coolant concentrations. Coolant concentration may be reduced, as necessary, depending on the wheel manufacturer's recommendations.***

- 4) When the spray guard brushes are dry, clean any buildup of glass grind from the brushes by running a long thin object back and forth between the bristles. The brush can also be removed for a more thorough cleaning, or replaced by removing the two screws in the brush mounting bracket.

**GRINDING AND POLISHING WHEELS****DIAMOND GRINDING WHEEL**

Diamond wheels, depending on manufacturer and base metal bond, vary considerably in service life from ½ million to over 1½ million linear inches (12,700m to over 38,100m). But they require periodic dressing. The groove in the wheel must be dressed according to the following procedure.

- 1) Remove front window to expose the diamond wheel.

**WARNING!**

**Be extremely careful while performing the dressing operation as directed in Step 3.**

- 2) The coolant pump must be "OFF" whenever dressing grinding or polishing wheels.
- 3) Turn the diamond wheel motor ON until it reaches full operating speed and then turn it "OFF". Quickly apply a CRL Cat. No. 46205871 dressing stone or equivalent, soaked in diamond wheel coolant solution or water, to the wheel groove while rocking it back and forth and pressing very hard as the wheel coasts to a stop. While holding the stone in the groove, apply pressure and rotate the wheel by hand in the opposite direction four or five revolutions to attain proper diamond exposure.

**SECTION 6 (continued)*****NOTE***

***Wheel dressing must be performed with the coolant pump "OFF", with the dressing stone thoroughly wetted.***

- 4) Repeat Step 3 several times and test the results by running a sample piece of glass.

**POLISHING WHEEL**

When the edger is used for polishing the edge of the glass, it is mandatory to use a special polishing wheel designed for a high RPM application. The polishing wheel has a short service life and must be grooved to the contour of the glass edge that is produced by the diamond wheel. This can be done by two methods. The first is to run glass through the edger while adjusting the (polishing) wheel until the entire glass edge is polished, repeating with as many passes as necessary.

***CAUTION!***

**Never exceed the maximum RPM on the polishing wheel. Inspect the wheel before mounting and using. If damaged, discard the wheel.**

The second method is to run a dressing board through the edger as you would a piece of glass. The board is ground to shape by the diamond wheel. Reposition the polishing wheel so it runs in the path of the glass or board. Then run the dressing board over the polishing wheel. This must be done a few times while adjusting the (polishing) spindle "UP" to ensure that an adequate groove is produced on the polishing wheel.

In both methods, turn the coolant pump "ON" to start the flow of coolant to the wheel. Press the spindle motor start button to start the operation of the wheel. Turn the conveyor "ON-FORWARD".

**SECTION 6 (continued)****MOUNTING DIAMOND/POLISHING WHEELS**

- 1) Clean the surface of the grind wheel hub where the wheel makes contact and clean out the drain hole in the slinger.
- 2) Clean the inside diameter of the wheel and lightly grease it with the lubricant provided (NOTE: the polishing wheel does not require a lubricant).
- 3) Align the mounting holes in the wheel with the tapped holes in the hub. Do not pound on the wheel. If necessary, use a longer  $\frac{1}{4}$ -20 socket head cap screw to draw the wheel on to the hub, tightening it progressively.
- 4) Install the lock washers and the socket head cap screws and tighten. Use 1"(25mm) long screws when mounting a  $\frac{1}{4}$ " (6.3mm) glass wheel only. If mounting two wheels, use longer screws.
- 5) When mounting two diamond wheels, always mount the  $\frac{1}{4}$ " glass wheel first. If mounting a polishing and a grind wheel, mount the polishing wheel first.

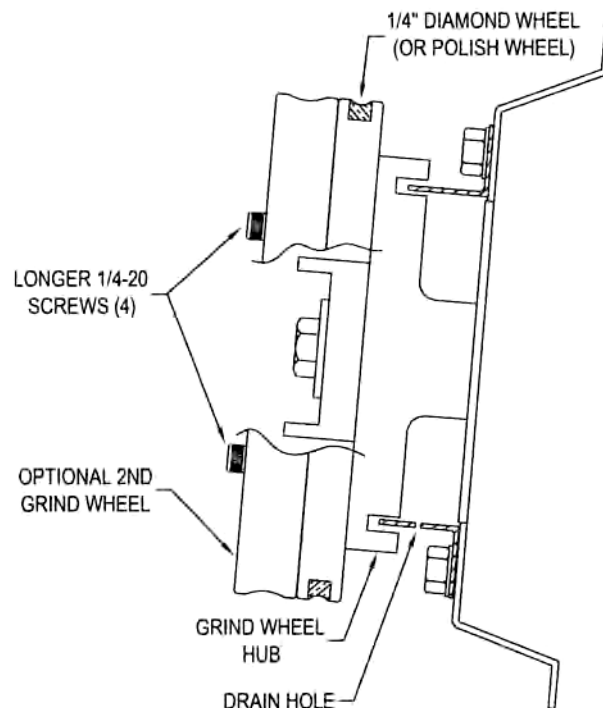
**DIAMOND WHEEL ONLY:**

Install two  $\frac{1}{4}$ -20 x  $\frac{1}{2}$  long hex head cap screws into the two tapped holes on the diamond wheel. These two holes are used as jack screw holes for removing the wheel. These screws will keep residue out of the threads.

## SECTION 7

### **TROUBLE SHOOTING PROCEDURES**

<b>PROBLEM</b>	<b>POSSIBLE SOLUTION</b>
Glass rides up in grinding compartments	<ul style="list-style-type: none"> <li>Check the coolant</li> <li>Dress the diamond wheel</li> <li>Check the infeed &amp; outfeed levelness</li> <li>Check for glass interference with the outfeed rollers</li> <li>Interference of glass with glass racks or rollers</li> <li>Decrease depth of cut</li> </ul>
Choppy edge	<ul style="list-style-type: none"> <li>Check the coolant</li> <li>Check the glass for interference with infeed rollers</li> <li>Redress the diamond wheel</li> <li>Check the motor mounting &amp; adjusting screws for tightness</li> <li>Re-true the diamond wheel</li> </ul>
Chipped edge or starred edge	<ul style="list-style-type: none"> <li>Check the coolant</li> <li>Check the wheel suitability for the glass thickness</li> <li>The wheel is turned to far and the steel is contacting the glass</li> <li>The wheel is worn out</li> <li>Try a finer wheel grit</li> <li>Run the wheel straight on</li> </ul>
Glass drops in conveyor section	<ul style="list-style-type: none"> <li>Check the infeed and outfeed for levelness</li> <li>Glass hitting the outfeed</li> </ul>

## **2 POSITION WHEEL STOP**

Mounting two wheels on a spindle motor will make switching from one wheel to the other less time consuming. Once you have set-up the machine to run on the wheel closest to the spindle motor, adjust the clamp collar against the handwheel.



When the machine is set-up to run the wheel closest to the operator, adjust the clamp collar against the handwheel.



These steps will allow you to switch between the wheels with minimal effort. Just turn the handwheel until it bottoms against the proper clamp collar. Always check the edge of the first piece of glass after making an adjustment. Always mount the narrower grinding wheel first (closest to the spindle motor) when using two wheels. This will make future changeovers easier.

## WHEEL POSITION DIAL INDICATORS

This feature allows accurate adjustment of new wheels, dual wheels or wheels of varying thicknesses for fast changeovers. The dial indicators are first zeroed in relation to the spindle adjusting plate for the horizontal plane (Fig. A) and the special indicator plate for the vertical plane (Fig. B). Avoid bottoming out the indicator. Once set, the readings should be recorded in a log specific to each wheel size or configuration used. When a changeover is required, the machine is adjusted to these readings. On dual configurations, always mount the narrower grinding wheel closest to the spindle motor. Check the edge of the first piece of glass after adjusting.

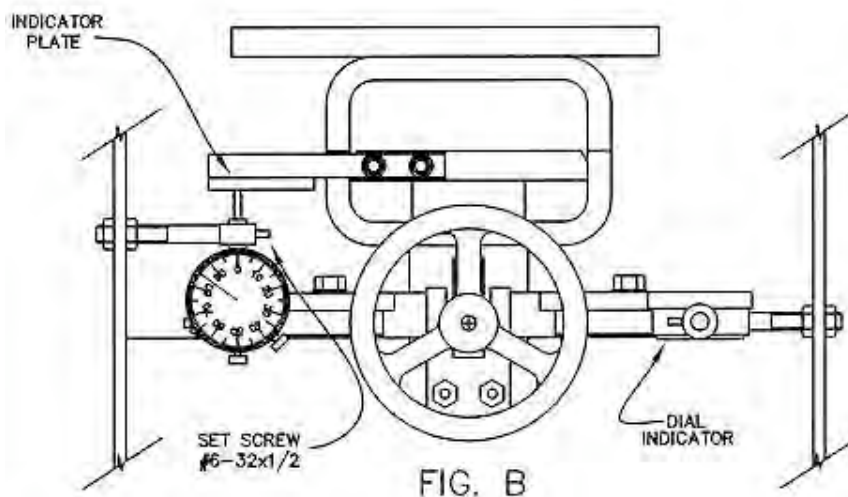
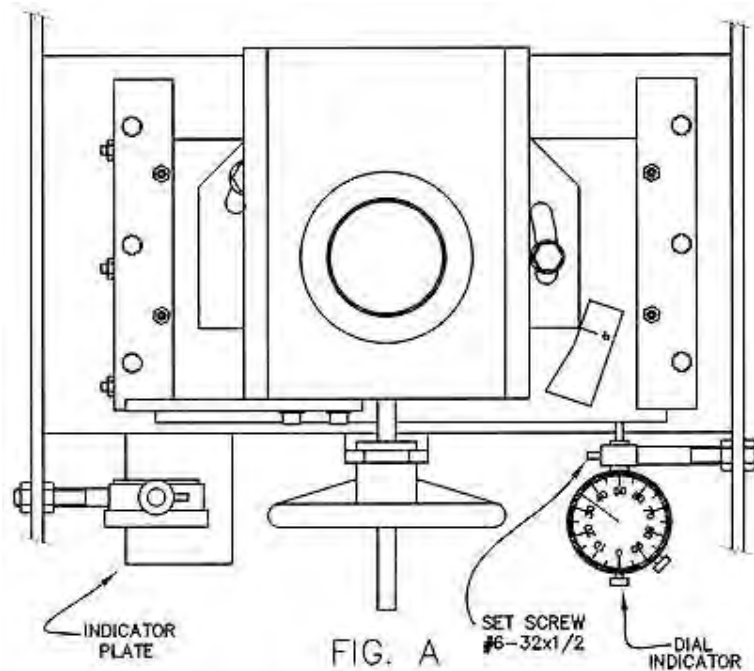

---

## **TERMS AND CONDITIONS MACHINERY WARRANTY STATEMENT**

C.R. LAURENCE CO., INC. ("SELLER") WARRANTS PRODUCTS OF ITS MANUFACTURE TO BE FREE FROM DEFECTS IN MATERIALS OR WORKMANSHIP IN NORMAL USE FOR (12) MONTHS FROM THE DATE OF SHIPMENT (UNLESS A SHORTER PERIOD IS PROVIDED ELSEWHERE IN THIS DOCUMENT).

SELLER'S OBLIGATION AND BUYER'S EXCLUSIVE REMEDY SHALL BE LIMITED TO REPAIR OR REPLACEMENT, AT SELLER'S SOLE OPTION, OF DEFECTIVE PARTS WITHIN THE WARRANTY PERIOD, PROVIDED BUYER GIVES SELLER IMMEDIATE WRITTEN NOTICE OF SUCH ALLEGED DEFECTS, AND, IF REQUESTED BY SELLER, RETURNS THE DEFECTIVE PARTS TO SELLER'S FACTORY PREPAID BY BUYER FOR SELLER'S INSPECTION. THE WARRANTIES CONTAINED HEREIN ARE IN LIEU OF ANY OTHER WARRANTY, EXPRESSED OR IMPLIED, INCLUDING ANY WARRANTY OF MERCHANTABILITY OR FITNESS FOR PURPOSE. SELLER SHALL IN NO EVENT BE LIABLE FOR CONSEQUENTIAL DAMAGES.

WARRANTIES HEREUNDER SHALL NOT APPLY TO ANY EQUIPMENT THAT HAS BEEN DAMAGED BY MISUSE, NEGLIGENCE, ACCIDENT, OR FAILURE TO PERFORM MAINTENANCE. THIS WARRANTY SHALL BE NULL AND VOID (1) IF THE MACHINE IS USED IN A MANNER CONTRARY TO INSTRUCTIONS OR AFTER MALFUNCTION IS NOTICED; (2) IF THE BUYER DOES NOT HONOR TERMS OF PAYMENT; (3) IF THE MACHINE IS MODIFIED OR ALTERED.

### **EQUIPMENT RESOLD BY SELLER**

IN THE CASE OF EQUIPMENT FURNISHED BY SELLER BUT NOT OF SELLER'S MANUFACTURE, SELLER'S LIABILITY TO BUYER HEREUNDER IS LIMITED TO SUCH WARRANTY AS THE MANUFACTURER MAKES TO SELLER, BUT IN NO CASE GREATER THAN (12) MONTHS FROM DATE OF SHIPMENT BY SELLER.

### **LIMITATION OF LIABILITY**

SELLER'S SOLE REMEDY SHALL BE REPAIR OR REPLACEMENT OF DEFECTIVE PRODUCT. IN NO EVENT SHALL SELLER BE LIABLE FOR ANY OTHER REMEDY (INCLUDING, BUT NOT LIMITED TO, INCIDENTAL OR CONSEQUENTIAL DAMAGES FOR LOST PROFITS, LOST SALES, INJURY TO PERSONS OR PROPERTY OR ANY OTHER INCIDENTAL OR CONSEQUENTIAL LOSS) OR PUNITIVE DAMAGES.

### **DISPUTE RESOLUTION**

ANY DISPUTE BETWEEN THE CUSTOMER AND SELLER SHALL BE SETTLED BY ARBITRATION BETWEEN THE PARTIES, UNDER THE RULES OF THE AMERICAN ARBITRATION ASSOCIATION, CHICAGO, IL SUCH ARBITRATION SHALL TAKE PLACE IN CHICAGO, IL, USA WITHIN 90 DAYS AFTER A REQUEST FOR ARBITRATION HAS BEEN FILED BY ONE OF THE PARTIES. BOTH PARTIES IRREVOCABLY CONSENT TO JURISDICTION IN COOK COUNTY, ILLINOIS.

### **LAW**

ALL CONTRACT AND OTHER CLAIMS (WHETHER BASED ON CONTRACT, TORT, EQUITY, TREATY, OR CODE) WITH RESPECT TO THE PRODUCTS SOLD AND ALL CLAIMS WITH RESPECT TO THE OPERATION AND USE OF THE PRODUCTS SHALL BE GOVERNED BY, AND CONSTRUED IN ACCORDANCE WITH THE LAWS OF THE STATE OF ILLINOIS, USA. THE SALES CONTRACT SHALL NOT BE GOVERNED BY THE UNITED NATIONS CONVENTION ON CONTRACTS FOR THE INTERNATIONAL SALES OF GOODS.

### **INVALIDITY OF PROVISIONS**

IF ANY PROVISIONS OF THESE TERMS AND CONDITIONS ARE HELD TO BE INVALID, ILLEGAL OR UNENFORCEABLE, THE REMAINING PROVISIONS OF THESE TERMS AND CONDITIONS SHALL NOT IN ANY WAY BE AFFECTED OR IMPAIRED THEREBY.

C.R. Laurence Co., Inc.  
Glass Machinery Division  
5501 West Ogden Avenue, Cicero, IL 60804, U.S.A.



## ADDENDUM PUMP MAINTENANCE



The NK series pumps must be used in submerged type applications. The pump is to be placed with the screen as the base or on the two support legs opposite power cord entry. If the surface is sandy or muddy, provide a smooth surface for the pump when placed with the intake down.

The NO-Korode (NK) pumps are designed to be used in mild acids, alkalies and hard water applications. Before you use the pump in any of these applications, please check the Little Giant CRC chart (form # 995516) for compatibility of fluids that come in contact with pump parts. The pump materials consist of: glass-filled nylon housing, nylon volute, plate, impeller and elbow, stainless steel motor shaft and fasteners, nitrile square cut seal (between volute and plate), Viton shaft seal and polyethylene screen. The cord jacket is PVC material. Other plastic parts are nylon.

Do not restrict the intake side of the pump. Restricting intake may cause damage to the shaft seal. If less flow is required, restrict the discharge side of the pump. For example, if plastic tubing is used, place a clamp on the tubing to restrict the flow by squeezing the tubing.

Do not let the unit operate dry. It is designed to be cooled by the pumping fluid. You may damage the seal and the motor may fail if the pump is allowed to run dry.

If the unit is going to be idle for a period of time, follow the cleaning instructions that follow before you store the unit. Do not allow the unit to freeze in wintertime. Freezing may cause cracking or distortion of the plastic parts which will destroy the pump.

### SERVICE INSTRUCTIONS



**MAKE CERTAIN THAT THE MACHINE IS DISCONNECTED FROM THE POWER SOURCE BEFORE ATTEMPTING TO SERVICE OR REMOVE ANY PUMP COMPONENT.**

- 1) The pump is permanently lubricated. Oiling IS NOT required. Do not, in any case, open the sealed portion of the unit or remove housing screws.
- 2) Periodic cleaning of the pump parts will prolong the LIFE and EFFICIENCY of the pump. Refer to Fig.1 for assembly and disassembly of the pumping head.
- 3) First remove the screen from the pump. Then remove the (3) screws as indicated by the arrows. (DO NOT remove any other screws, which may be exposed).
- 4) Lightly clean any corrosion or debris which may clog the impeller. Use a brush and penetrating oil and lightly scrape to remove encrusted material.
- 5) Turn the impeller by hand to make sure it turns freely. Set pump down so you are not touching pump and the impeller is not touching anything. Connect the Edger to power source, turn conveyor switch "ON" to see if the impeller turns. a) If it is rotating, turn conveyor switch "OFF", disconnect from power source and install parts in reverse order in which they were removed. b) If it does not rotate, if pump is tripping circuit breakers, or not operating properly after cleaning, call CRL Glass Machinery Parts Department for ordering a replacement pump. DO NOT attempt repairs yourself.
- 6) Be sure the power cord is in good condition and contains no nicks or cuts.

**PUMP ASSEMBLY**

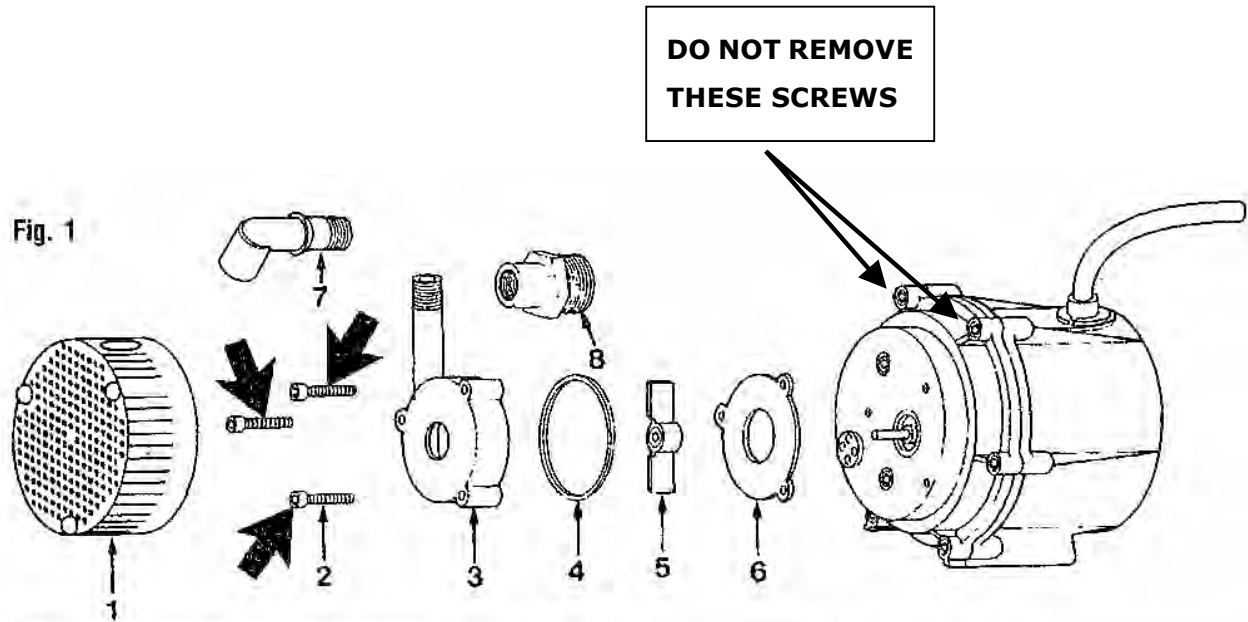

ITEM	PART #	DESCRIPTION	CATALOG NO./MODEL NO.									
			526003 NK-1	526076 NK-1	527003 NK-2	527016 NK-2	527076 NK-2	527176 NK-2	527180 NK-2	527300 NK-2UL-WG	527380 NK-2UL-FWG	
1	101376	SCREEN, POLYETHYLENE	1	1	1	1	1	1	1	1	1	
2	902417	SCREW, #8-18 x 1", SS	3	3	3	3	3	3	3	3	3	
3	116375	VOLUTE, SMOOTH, NYLON	1	1	1	1	1	1	1	1		
3	116376	VOLUTE, WG (not shown)		1			1			1	1	
4	928007	SEAL RING, SQ. CUT, NITRILE	1	1	1	1	1	1	1	1	1	
5	116437	IMPELLER ASSEMBLY, NYLON	1	1	1	1	1	1	1	1	1	
6	126377	BACKPLATE, NYLON	1	1	1	1	1	1	1	1	1	
7	943076	ELBOW, 90°, NYLON	1	1	1	1	1	1	1	1		
8	599022	ADAPTOR, 3/4 GHT x 1/4 FNPT						1				

Factory Replacement Parts and Accessories for the VE-1P/AU11 Edger

**Coolant Pump**

This is the correct Pump to maintain proper coolant circulation.

CAT. NO.	DESCRIPTION
42500170	(for Cat. No. VE1P) 110V AC Coolant Pump
42500160	(for Cat. No. AU11) 220V AC Coolant Pump

Minimum order is one each.



**Coolant Hose and Valve**

Controls and directs coolant to the Diamond and Polish Wheels.

CAT. NO.	DESCRIPTION
42333006	12" Coolant Hose w/Fittings (no valve)
42333008	Valve only

Minimum order is one each.



**Wheel Mounting Bolt Kit**

These are the correct stainless steel bolts for securing the Polish and Diamond Wheels. Set includes four flat washers, four lock washers and four bolts each of five lengths: 1" (25 mm), 1-1/4" (32 mm), 1-1/2" (38 mm), 1-3/4" (44 mm), and 2" (51 mm).

CAT. NO.	DESCRIPTION
39528200	Kit of all 20 Bolts

Minimum order is one bolt kit.



Bolts should be 1/4" (6 mm) longer than the total thickness of the wheel(s) being used.

**Hex/Allen T-Wrench**

Use the correct Hex/Allen T-Wrench to work with the Wheel Bolts above.

CAT. NO.	DESCRIPTION
46906580	T-Wrench

Minimum order is one each.



**Conveyor Roller and Shoulder Screw**

These are the rubber Rollers that support the glass as it enters and exits the Edger.

CAT. NO.	DESCRIPTION
16300160	Conveyor Roller
36988804	Roller Shoulder Screw

Minimum order is one each.



**Platen Belt**

The rubber Platen Belt that moves the glass through the Edger. Replace yours if it is stretched, cracking or contaminated.

CAT. NO.	DESCRIPTION
43313220	Drive Belt

Minimum order is one each.



**Wheel Position Dial Indicator**

Dial Indicators allow precise positioning of Grind and Polish Wheels. Record settings for quick repositioning of Wheels during changeover.

CAT. NO.	DESCRIPTION
49000510	Replacement Dial Indicator (1 only)
39700000	Dial Indicator Kit, (2)Complete*
39700001	Dial Indicator Kit, (2)Complete**

\* for machines built BEFORE April 1, 2003 (see serial No. on machine)  
 \*\* for machines built AFTER April 1, 2003 (see serial No. on machine)  
 Minimum order is one each.

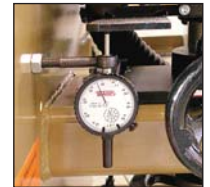

**Pressure Roller and Bushings**

Pressure Rollers hold the glass against the platen belt. Bearings can wear and must be replaced for correct alignment. Three rollers, three upper and three lower Bearings needed per Edger.

CAT. NO.	DESCRIPTION
46300230	4" Pressure Roller
39663102	Lower Pressure Roller Bearings
39663101	Upper Pressure Roller Bearings

Minimum order is one each.



**Brush Shields**

Brush Shields keep water inside the Edger and off of your work area. If yours are worn or contaminated, replace them with these parts. Two Main and two End Shields per Edger.

CAT. NO.	DESCRIPTION
39223200	Main Brush Shield
39021400	End Brush Shield

Minimum order is one each.



**Rubber Wiper**

These small rubber "doors" keep water inside of the Edger. Two needed for each Edger.

CAT. NO.	DESCRIPTION
39021500	Rubber Wiper

Minimum order is one each.



**Replacement Glass Rack Rail**

Rails for the current model VE1P. They DO NOT FIT older models without additional parts and modifications. Each is cut to size shown.

CAT. NO.	DESCRIPTION
39983001	120-3/4" Glass Rack Rail
39983002	49-7/8" Glass Rack Rail
39983003	46" Glass Rack Rail

Minimum order is one each.



**End Cap for Rack Rail**

These end caps fit on all the Glass Rack Rails used on various models of the VE1P Edger.

CAT. NO.	DESCRIPTION
46300079	Rack Rail End Cap

Minimum order is one each.



Factory Replacement Parts and Accessories for the VE-1P/AU11 Edger

**CRL EDGER WHEELS**



Pencil

**Diamond Pencil Edge Wheels**

7" (178 mm) diameter Diamond Wheel for pencil edge profiling. 140-170 grit.

CAT. NO.	APPLICATION
36443213	For 1/8" to 1/4" (3 to 6 mm) glass
36881012	For 3/16" to 3/8" (5 to 10 mm) glass
38404909	For 1/4" to 1/2" (6 to 12 mm) glass

Minimum order is one each.



Flat & Seam

**Diamond Flat and Seam Wheels**

7" (178 mm) diameter Diamond Wheel for Flat and Seam profiling. 140-170 grit.

CAT. NO.	APPLICATION
38533510	For 1/8" to 1/4" (3 to 6 mm) glass
38386909	For 3/16" to 3/8" (5 to 10 mm) glass
38517503	For 1/4" to 1/2" (6 to 12 mm) glass

Minimum order is one each.



Miter

**Diamond 30 Degree Miter Wheel**

7" (178 mm) diameter Diamond Wheel for 30 degree miter profiling. 140 grit.

CAT. NO.	APPLICATION
38677802	For 1/8" to 1/2" (3 to 12 mm) glass

Minimum order is one each.



**Grind Wheel Hub**

Holds 2 wheels and fits the spindle motor on the VE1P/AU11. Use to mount extra set-ups.

CAT. NO.	APPLICATION
38430304	Grind Wheel Hub

Minimum order is one each.



**Orange Polish Wheel**

For 1/8" to 1/2" (3 to 12 mm) glass. 7-1/4" diameter x 3/4" (184 mm x 19 mm) thick. Always use the original Orange Wheel for best results.

CAT. NO.	APPLICATION
39666000	For 1/8" to 1/2" (3mm to 12mm) glass

Minimum order is one each.



**CRL EDGER ACCESSORIES AND PARTS**

**Board Dressing Plates and Sticks**

8" x 6" (203 mm x 152 mm) Board Dressing Plates are used on the Polishing Wheel by running them through the machine like a piece of glass.

6" x 2" (152 mm x 51 mm) Dressing Sticks are used to dress the Diamond Wheels by hand from the front of the machine.

CAT. NO.	DESCRIPTION
46205880	1/4" (6 mm) Thick Board Dressing Plate
46205881	3/8" (10 mm) Thick Board Dressing Plate
46205882	1/2" (12 mm) (Thick Board Dressing Plate
46205871	1/4" (6 mm) Thick Dressing Stick

Minimum order is one each.

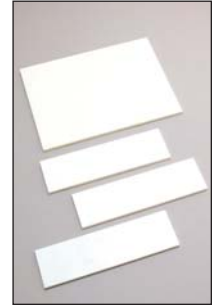

**Synthetic Blue Powder Coolant**

Biodegradable, anti-foaming Coolant Powder mixes with water for high lubricity. Inhibits rust and dissipates heat. Mix ratio is 100:1.

CAT. NO.	DESCRIPTION
2651005	1 lb. (.453 kg.) Bag of Coolant

Minimum order is one each.



**Glass Rail Rack Parts for VE1P/AU11 Edgers built in June 2013 and after**

Each 39982900 Support Bracket requires a 39501206 Spacer Tube.

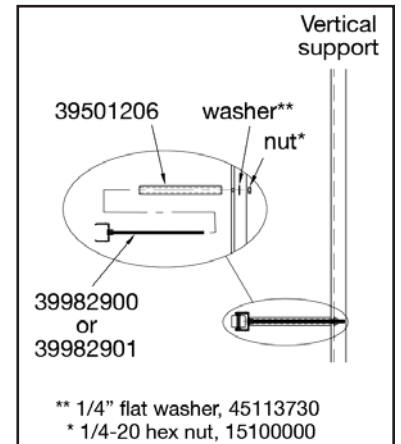

**Glass Rail Support Bracket**

The one-piece bracket slides onto the new Glass Rail Rack sections.

CAT. NO.	DESCRIPTION
39982900	Rail Support Bracket

Minimum order is one each.



**Spacer Tube, Plastic**

Use these spacers over the above Rail Brackets.

CAT. NO.	DESCRIPTION
39501206	Bracket Spacer Tube

Minimum order is one each.

