

INSTALLATION INSTRUCTIONS

PREMIUM BALANCED DOOR WITH WORM GEAR TENSIONER

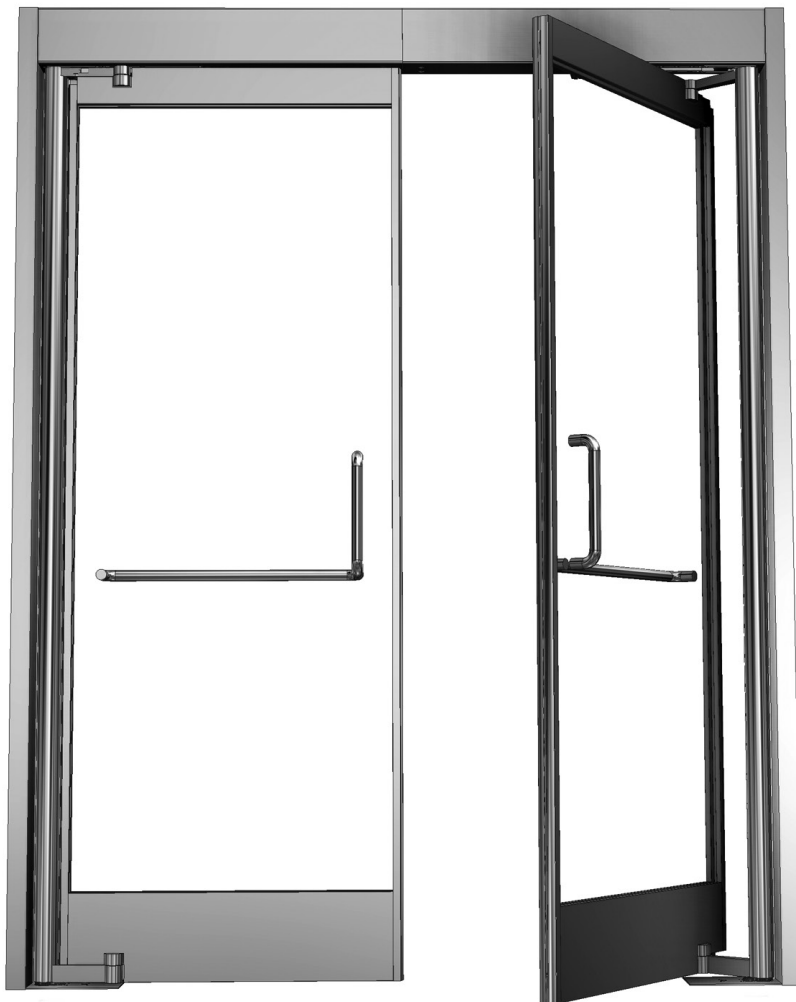

Phone: (800) 421-6144 • Fax: (800) 582-7501
crlaurence.com • usalum.com • crl-arch.com

11M0197

ORDER OF ASSEMBLY AND INSTALLATION

INTRODUCTION	3
STEP 1: CONFIRM YOUR SHIPMENT.....	3
STEP 2: CHECK ROUGH OPENING.....	3
STEP 3: VERIFY FLOOR CONDITION.....	3
STEP 4: INSTALL HEADER	4
STEP 5: INSTALL BASE PLATES - EXPOSED HINGE TUBE	5
STEP 5.1: INSTALL BASE PLATES - CONCEALED HINGE TUBE	6
STEP 6: INSTALL HINGE TUBE.....	7
STEP 7: INSTALL THE DOOR.....	8
STEP 8: ADJUST CLOSING FORCE.....	9
STEP 9: ADJUST CLOSER SPEED.....	9
STEP 10: ADJUST PIVOT BLOCK.....	10
COMPONENT OVERVIEW.....	11
MAINTENANCE.....	12
JOB SITE ESSENTIALS.....	13

IMPORTANT: READ THIS MANUAL THOROUGHLY BEFORE BEGINNING INSTALLATION.

C.R. Laurence, Inc. warrants all products manufactured by it and supplied hereunder to be free from defects in material and workmanship in accordance to our contract.

This warranty shall not apply to any products not manufactured by CRL, nor to any products which have been repaired or altered by others without CRL's written consent. This warranty shall not include failure of parts and materials due to improper installation, inadequate support of surrounding structures, and/or lack of proper maintenance.

INTRODUCTION

Thank you for choosing the Premium Balanced Door System by C.R. Laurence. We have made every effort to assure the utmost quality in materials and craftsmanship. Each unit has been fully assembled and factory tested prior to shipping. Please read this manual thoroughly before beginning installation.

STEP 1: CONFIRM YOUR SHIPMENT

Carefully open the shipping container and look for any damaged parts. Most orders are shipped knocked down and will require on-site assembly. Confirm that the door(s) height and width are approximately the same as the rough opening. Your package should include:

Fully Glazed Door(s)

Hinge Tube with Top and Bottom Pivot Arms

Header Assembly

Floor Mounted Gearbox

Threshold and Side Jambs

Options may include **Hinge Tube Cover**, **Handles**, **Stanley Operator Motor** and **Stanley Electrical Control Units**. Refer to your packing list for details.

If any parts are missing or damaged, call the C.R. Laurence Technical Sales Department immediately at **1-(800)-421-6144**. Refer to the order number on the packing list.

STEP 2: CHECK ROUGH OPENING

Verify that the rough opening is square and plumb. Refer to CRL Shop Drawings to confirm rough opening dimensions. It should be slightly larger than the finished door frame including header and threshold.

If automatic door options are required, make sure that all electrical wiring is completed to the rough opening and **NOT ENERGIZED**. Refer to the C.R. Laurence "Site Preparation" drawing and/or your job drawings to confirm all required electrical connections.

STEP 3: VERIFY FLOOR CONDITION

The floor directly below the rough opening should be clean and in good condition. It is critical that the floor be sound and level. The Premium Balanced Door threshold and pivot gear box mounts directly to the floor or sub floor surface. It must be able to support the system's weight and firmly hold the fasteners in place for the lifetime of the installation. It is also necessary for the floor to be level and square to the jambs to allow a smooth operation of the Balanced Door.

CRL PREMIUM BALANCED DOOR WITH WORM GEAR



NOTE: Medium to heavy usage of specified components may cause critical fasteners to loosen over time. C.R. Laurence recommends the use of **Cat.No. 24221** Loctite® 242®. It is designed for the locking and sealing of threaded fasteners which require normal disassembly with standard hand tools. The product cures when confined in the absence of air between close fitting metal surfaces and prevents loosening and leakage from shock and vibration. Suitable for applications on less active substrates such as plated surfaces, where disassembly with hand tools is required for servicing.

STEP 4: INSTALL HEADER

Open the interior header access panel(s) and remove all components except the cam assembly as shown. This reduces the weight of the header and allows access to any predrilled mounting holes. Be sure to mark the parts (L/R) because they are matched to the cam assembly.

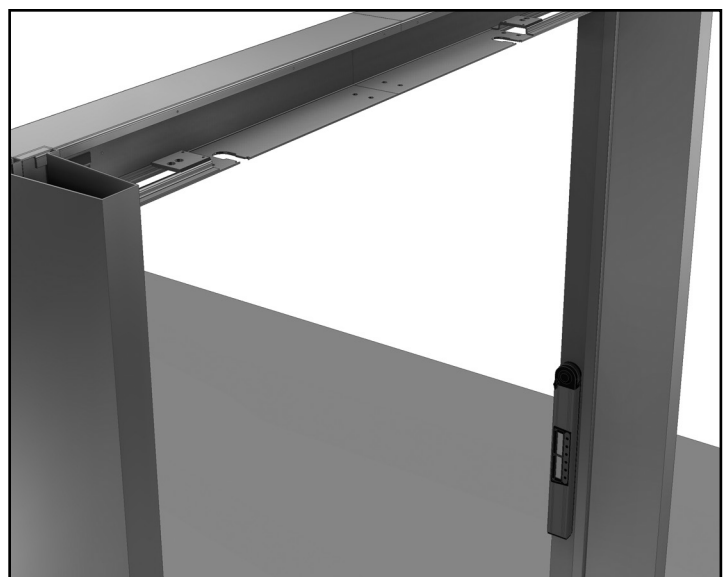
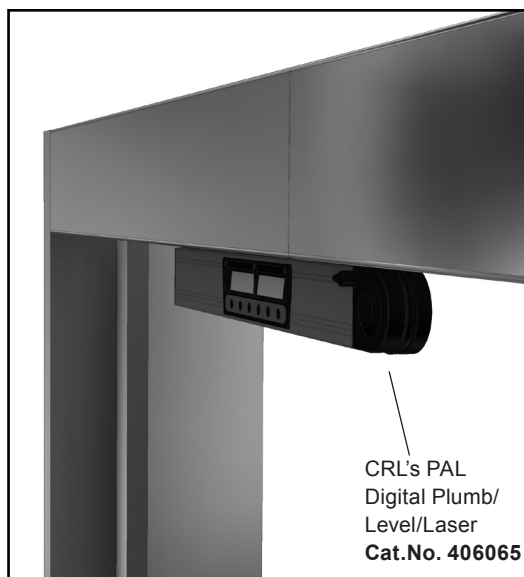
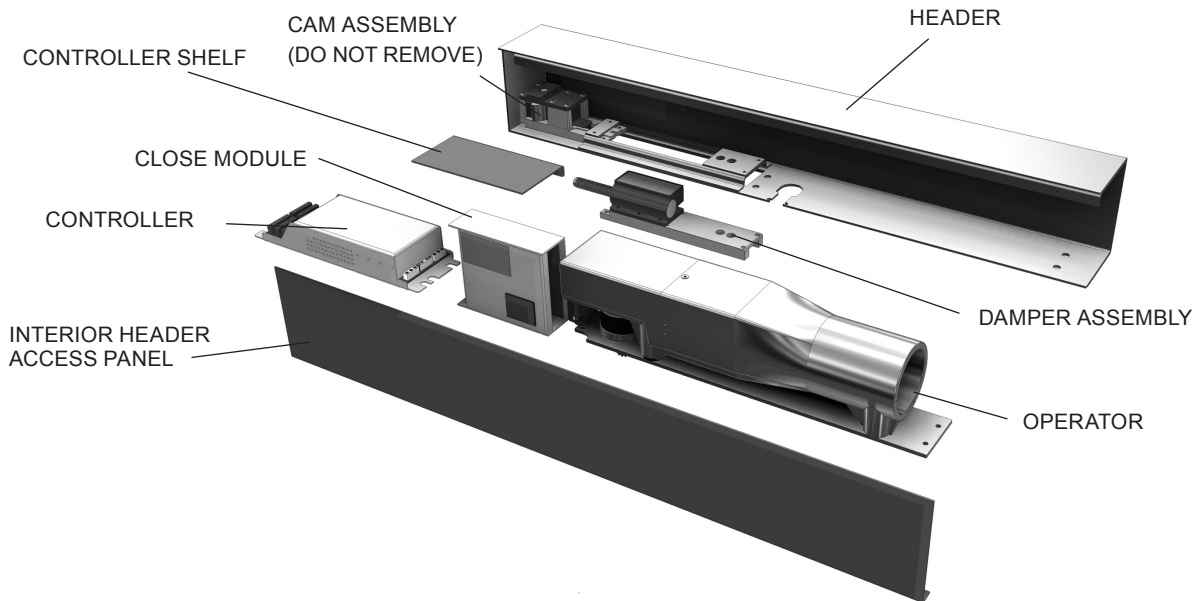

Level the header using a digital level and mount it to rough opening surfaces using appropriate fasteners. Pay particular attention to the height off the floor designated on the CRL Shop Drawings. The specified height dimensions are critical to proper operation and have a very small tolerance of (+/-) 1/32" (1 mm). After the header is mounted it will be difficult to move.

CRL PREMIUM BALANCED DOOR WITH WORM GEAR

STEP 5: INSTALL BASE PLATES - EXPOSED HINGE TUBE

Exposed tube installations use REF128 base plates placed at location and orientation shown below. Use CRL Cat.No. **BDPS105** Plumb Bob to correctly position each plate.

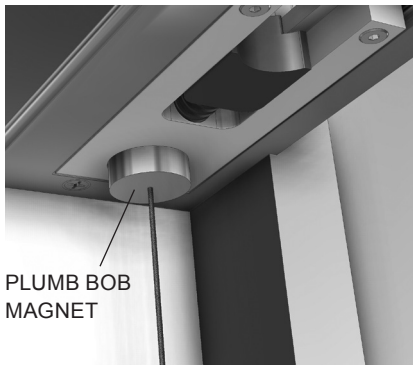

◀ (A) Attach Plumb Bob magnet to header. Move the base plate so Plumb Bob hovers over the pivot pin.

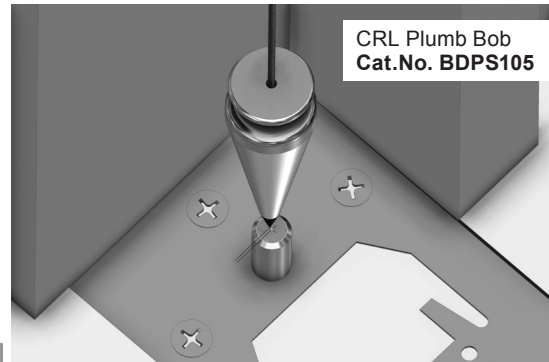

▶ (B) Shift each base plate 1/32" (1 mm) to the CENTER of the door opening. This will preload the pin location for the door weight.

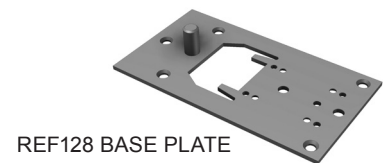
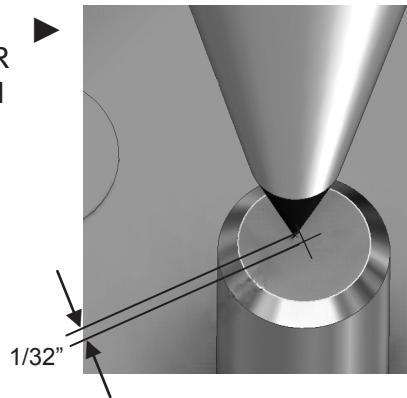

(C) Attach base plates to the floor with appropriate fasteners through the five countersink holes.

▶ (D) With the tension adjustment screw facing the interior, fit the tension adjuster over the pivot pin. Place a pivot shim on the offset tension adjuster to set the top pivot arm clearance. The proper shim will provide 1/8" (3 mm) clearance at the door top. Begin with the .031" shim. You will determine the correct shim in Step 6D.

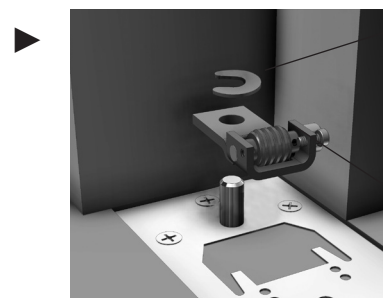

REF221 (.062")
REF222 (.031")
BOTTOM DOOR PIVOT SHIM

REF129
TENSION ADJUSTER
(SPECIFY LEFT/RIGHT)

(E) Install finish plates flush with the finished floor surface.



CRL PREMIUM BALANCED DOOR WITH WORM GEAR

STEP 5.1: INSTALL BASE PLATES - CONCEALED HINGE TUBE

When installing a Concealed Balanced Door System with a Worm Gear Tensioner, it is critical that the jambs be plumb and square with the header.

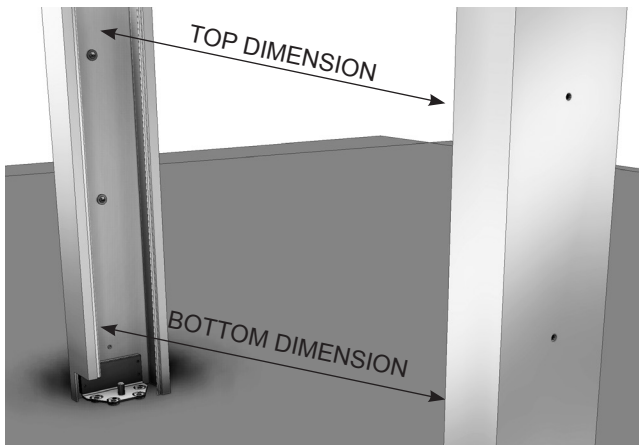

(A) Stand frame up and center the header inside the rough opening with shims. Plumb one jamb side and hold in place with shims or fasteners. Make sure that it is square with the header and that the header is level. Adjust the opposite jamb to plumb and level. Compare the top and bottom dimensions.

(B) Place REF148 base plates at location and orientation shown. Move the base plate so Plumb Bob hovers over the pivot pin.

REF148
BASE PLATE



(C) Shift each base plate $1/32"$ (1 mm) to the CENTER of the door opening. This will preload the pin location for the door weight.

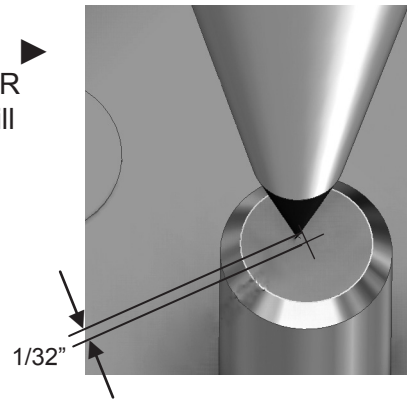

CRL Plumb Bob
Cat.No. BDPS105

(D) Attach both base plates to the floor surface with the appropriate fasteners. It is very important that the base plates are mounted to a solid surface capable of supporting the weight of the doors. Make sure they are level with each other.

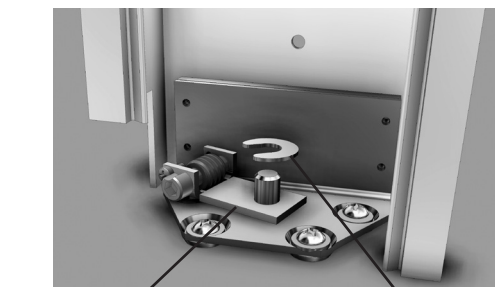
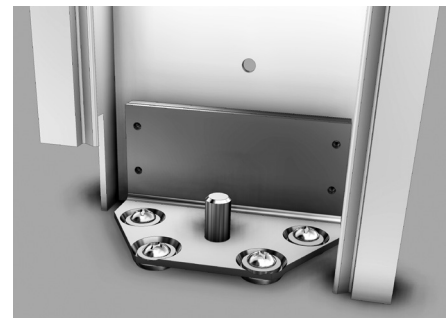

(E) With the tension adjustment screw facing the interior, fit the tension adjuster over the pivot pin. Place a pivot shim on the offset tension adjuster to set the top pivot arm clearance. The proper shim will provide $1/8"$ (3 mm) clearance at the door top. Begin with the .031" shim. You will determine the correct shim in Step 6D.

REF131LHCON (LEFT) OR
REF131RHCON (RIGHT)
TENSION ADJUSTER

REF221 (.062")
REF222 (.031")
BOTTOM DOOR PIVOT SHIM

CRL PREMIUM BALANCED DOOR WITH WORM GEAR

STEP 6: INSTALL HINGE TUBE

The hinge tube assembly carries the full weight of the glazed door and acts as an intermediate hinge to the Balanced Door System. It is very important to install and adjust it properly to achieve free and unrestricted movement.

(A) If double doors are supplied, use the shape of the pivot arms to identify the left and right hinge tubes.

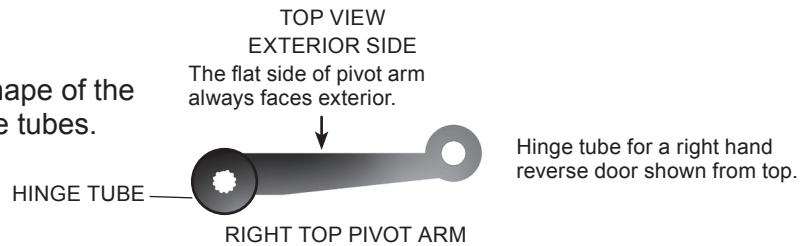

(B) Temporarily lower the cam to install the hinge tube.

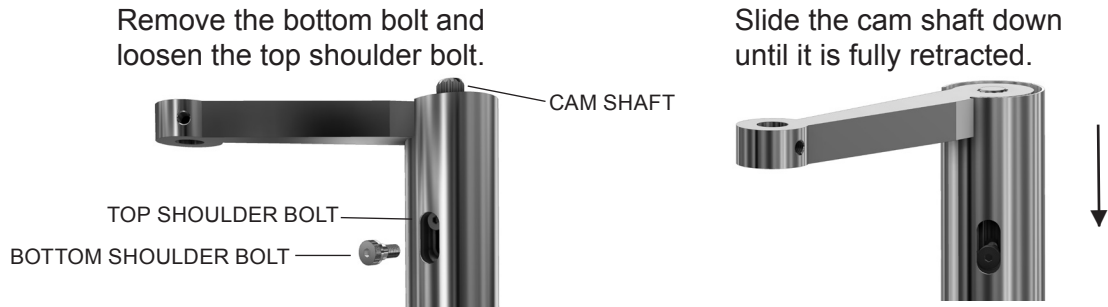

(C) Position hinge tube with pivot arms pointing towards the exterior. Place the bottom of the hinge tube over the floor pivot pin and turn until the gears mesh. Let it fall into place naturally. Do not force. Make sure the gears are engaged. Holding the tube vertical, apply a downward pressure to the bottom pivot arm with your foot until it is completely resting on the floor pivot pin.

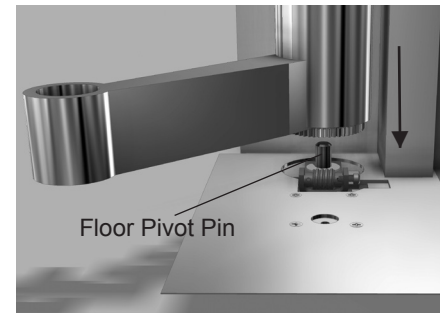

(D) Swing the top of the hinge tube into position in the header. The cam shaft lines up with the closer cam socket.

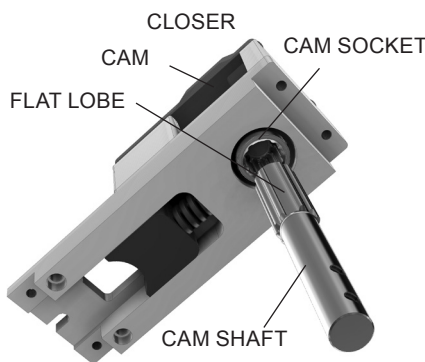

NOTE: The cam shaft fits only one way into the cam socket.

(E) Line the flat lobe of the cam shaft with the flat section in the cam socket. Apply upward sliding pressure on the cam shaft as you turn the cam from above. When they engage, raise the cam shaft until it stops. Apply **Cat.No. 24221** Loctite to bottom shoulder bolt and insert to hold cam in place. Remove the top shoulder bolt. Apply Loctite and re-insert. Tighten bolts completely.

When properly installed, the pivot arms swing freely in either direction without rubbing the header or threshold.

WARNING: In order to maintain full engagement of the cam shaft, do not exceed the 3/16" (5 mm) maximum gap between the top pivot arm and the bottom of the header. A greater gap will result in an unsafe condition.

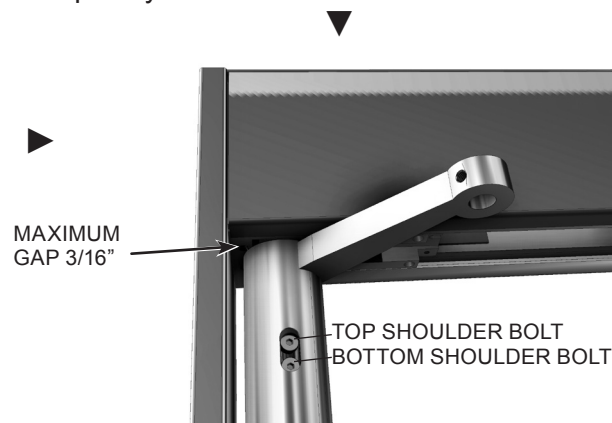

Cat.No. 24221
Loctite

STEP 7: INSTALL THE DOOR



Cat.No. 24221 Loctite

- ◀ (A) Replace the matched damper assembly. Using a large flat head screwdriver, pry the track up and into position. This will give you the leverage necessary to overcome the return spring pressure of the damper. When in place, attach the damper plate with 4 - 1/4" - 20 X 1" Socket Head Cap screws. Apply **Cat.No. 24221** Loctite to each screw and tighten securely.

- ▶ (B) Place the REF22 shim washer on the bottom pivot pin for proper gap spacing. Turn bottom pivot arm 45° to the interior side of door jamb. Adjust the spring tension at the bottom jamb plate if necessary.

Have an assistant hold the bottom pivot arm to keep the hinge tube stationary while installing the door.

Lift the door at an angle and set the bottom cup of the pivot block onto the pivot arm pin as shown. Hold the top of the door at an angle so it clears the header. Make sure the door is securely seated onto the bottom pivot arm by gently rocking it.

VIEW FROM EXTERIOR
BOTTOM PIVOT ARM BOTTOM PIVOT PIN

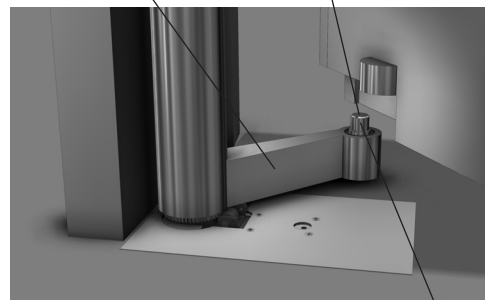

REF22 SHIM WASHER

NOTE: The REF22 shim washer is required for proper gap spacing. The recommended 3/32"-1/8" (2 - 3 mm) gap between the pivot arm and door rail cutout is set at the factory.

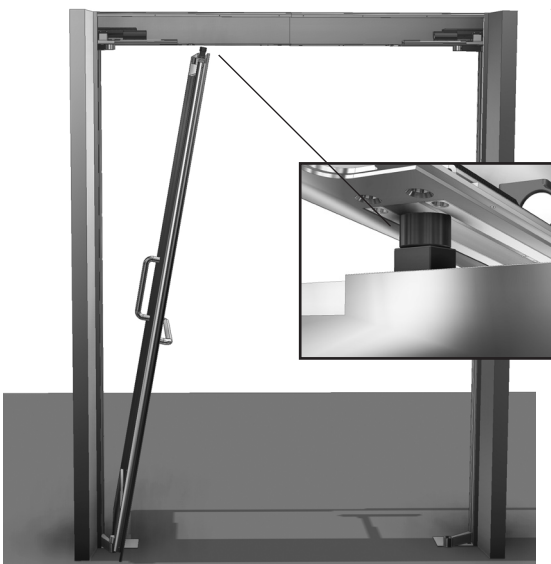

- ◀ (C) Swing the door upwards as you guide the top roller into the track. It may be necessary to remove any Magnalocks or door stops for additional clearance. Have an assistant hold the door vertical while you align the top pivot arm with the top pivot block.

- ▶ (D) Insert the top pivot arm shaft into top pivot arm as shown. The set screw fits into the groove to hold the top pivot arm shaft in place. Apply Loctite to set screw and tighten securely.

TOP PIVOT ARM



TOP PIVOT ARM SHAFT
GROOVE

Cat.No. 24221
Loctite

SET SCREW

- ▶ (E) Make sure the closing speed and latching speed valves are FULLY OPENED to allow the door to swing unrestricted. (Page 9, Step 9)

CAUTION: Use care when adjusting the damper valves. Excessive pressure may strip the threads. To fully open, gently turn each valve counterclockwise until it bottoms out against the damper body.

CRL PREMIUM BALANCED DOOR WITH WORM GEAR

STEP 8: ADJUST CLOSING FORCE

Use the tension adjuster assembly at the base of each hinge tube to adjust the closing force of the doors.

TENSION ADJUSTER ASSEMBLY

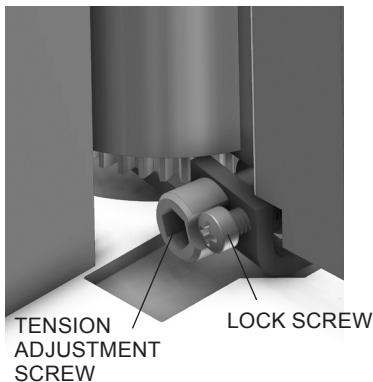

NOTE: Both damper valves should be fully open from Step 7E. If not, carefully open them before adjusting the closing spring force.

Remove the lock screw to change the closing force setting. Turn the tension adjustment screw until the required closing force is reached. Replace the lock screw to set.

STEP 9: ADJUST CLOSER SPEED

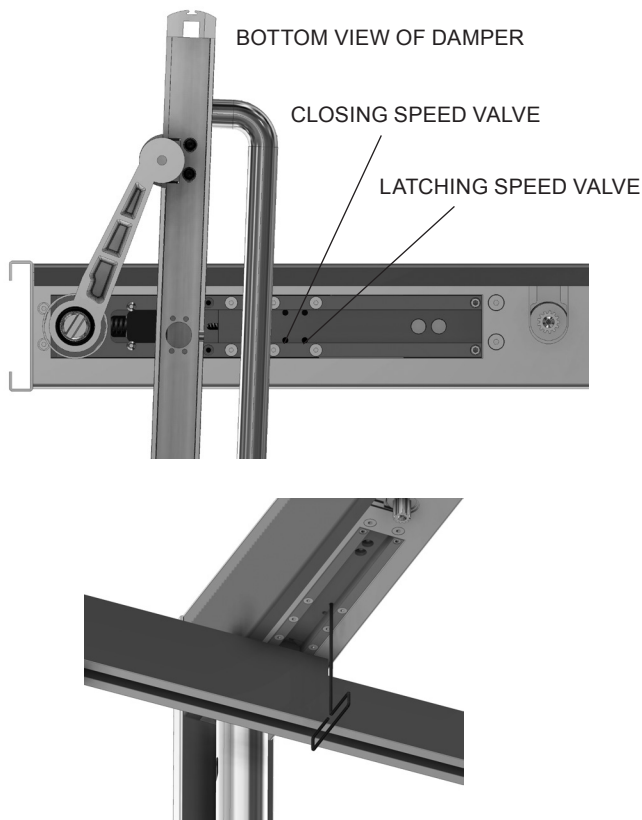

The damper is a two stage device that regulates the speed at which manual closing occurs. The valves should be fully opened from Step 8.

Have an assistant open the door from the exterior side to the maximum position. Turn the closing speed valve 1/4 turn. While gently holding it to prevent slamming, let the door fully close two times. Repeat the procedure until the door closes at a desired rate of speed.

Repeating the same cycling procedure, close the latching speed valve until you see a noticeable speed drop at the last 10 -12" of travel. You may need to readjust the closing speed valve until you reach a desired overall performance. Each valve adjustment affects the other.

Optimum closing action requires a delicate balance between the closing speed, latching speed and spring tension. Adjustment patterns will also vary from one door to another. Be sure to let the door cycle several times before changing the settings.

USE 5/16" HEX WRENCH TO ADJUST DAMPER VALVES.
(LOOSEN=COUNTERCLOCKWISE)

CRL PREMIUM BALANCED DOOR WITH WORM GEAR

STEP 10: ADJUST PIVOT BLOCK

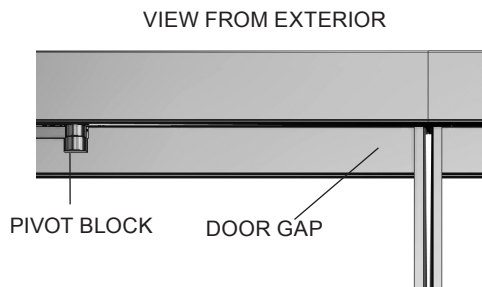

The adjustable pivot blocks located on the top and bottom of each door can be used to reduce small gaps and misalignments. The retaining screws are easily accessible without removing the door.

Open the door 45 degrees and block the bottom outside stile up off the floor with tapered wood shims. Only adjust one pivot block at a time. Loosen but do NOT remove the retaining screws. Adjust to the desired gap by adding or removing shims. Tighten the retaining screws, close door and check gaps. Misalignments up to 1/4" can be corrected with this procedure.

WARNING: Do not attempt this procedure without an assistant. Heavy, uncontrolled doors can cause serious injuries. Do NOT remove the retaining screws.

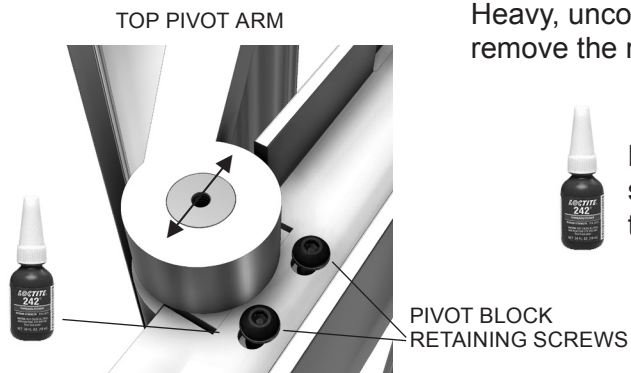

NOTE: After adjusting door alignment. Remove one screw at a time. Apply **Cat.No. 24221** Loctite® 242® to threads and re-insert.

TOP VIEW REFERENCE

RIGHT HAND REVERSED DOOR SHOWN

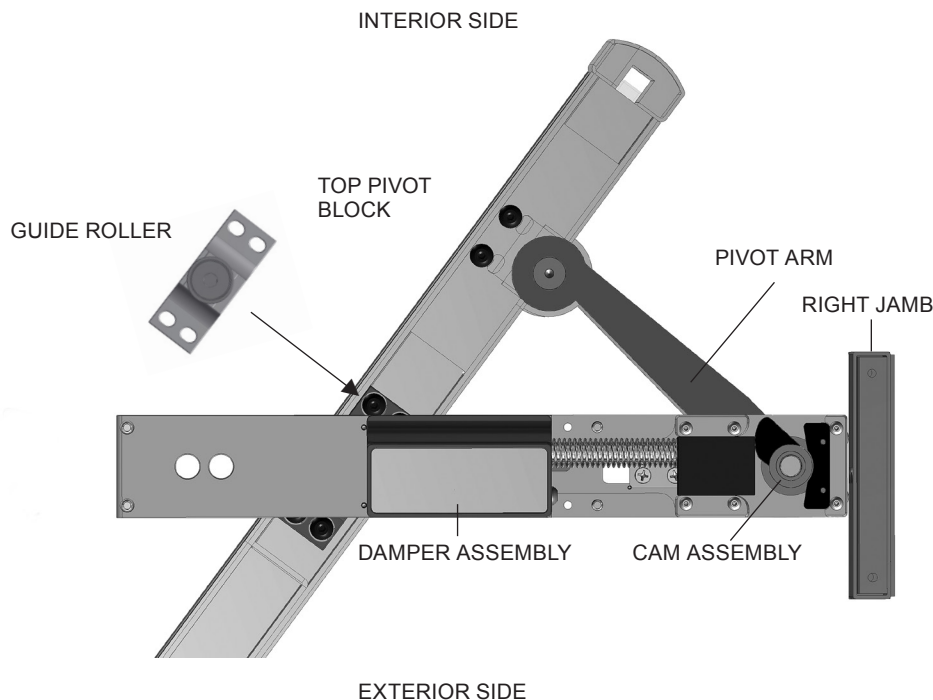

COMPONENT OVERVIEW

HEADER DETAIL SHOWN FROM INTERIOR

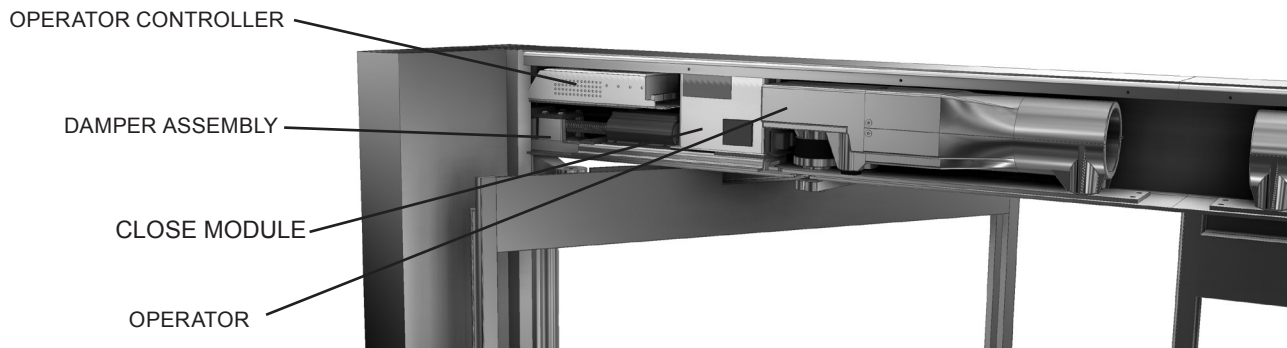

EXTERIOR VIEW

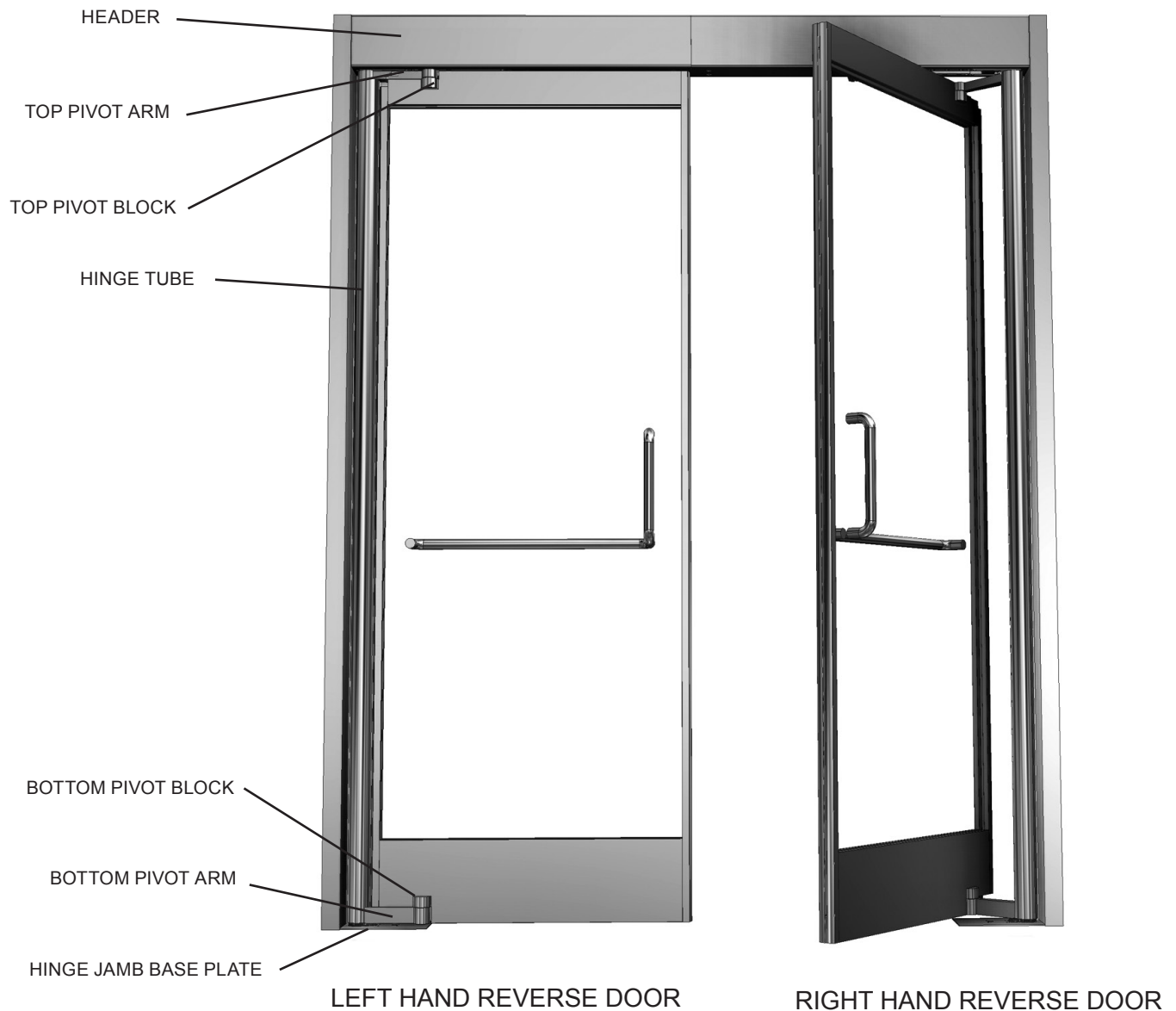

MAINTENANCE

Proper maintenance is critical to the life and operation of the Premium Balanced Door System. It is important to regularly clean environmental debris from areas adjacent to moving parts such as bearings, roller tracks and gear assemblies.

DO NOT LUBRICATE MOVING PARTS. Each component is shipped from the factory with ample lubrication and if kept clean will provide a long service life. Compressed air, soft clean towels and a small brush are recommended for most cleaning and maintenance procedures.

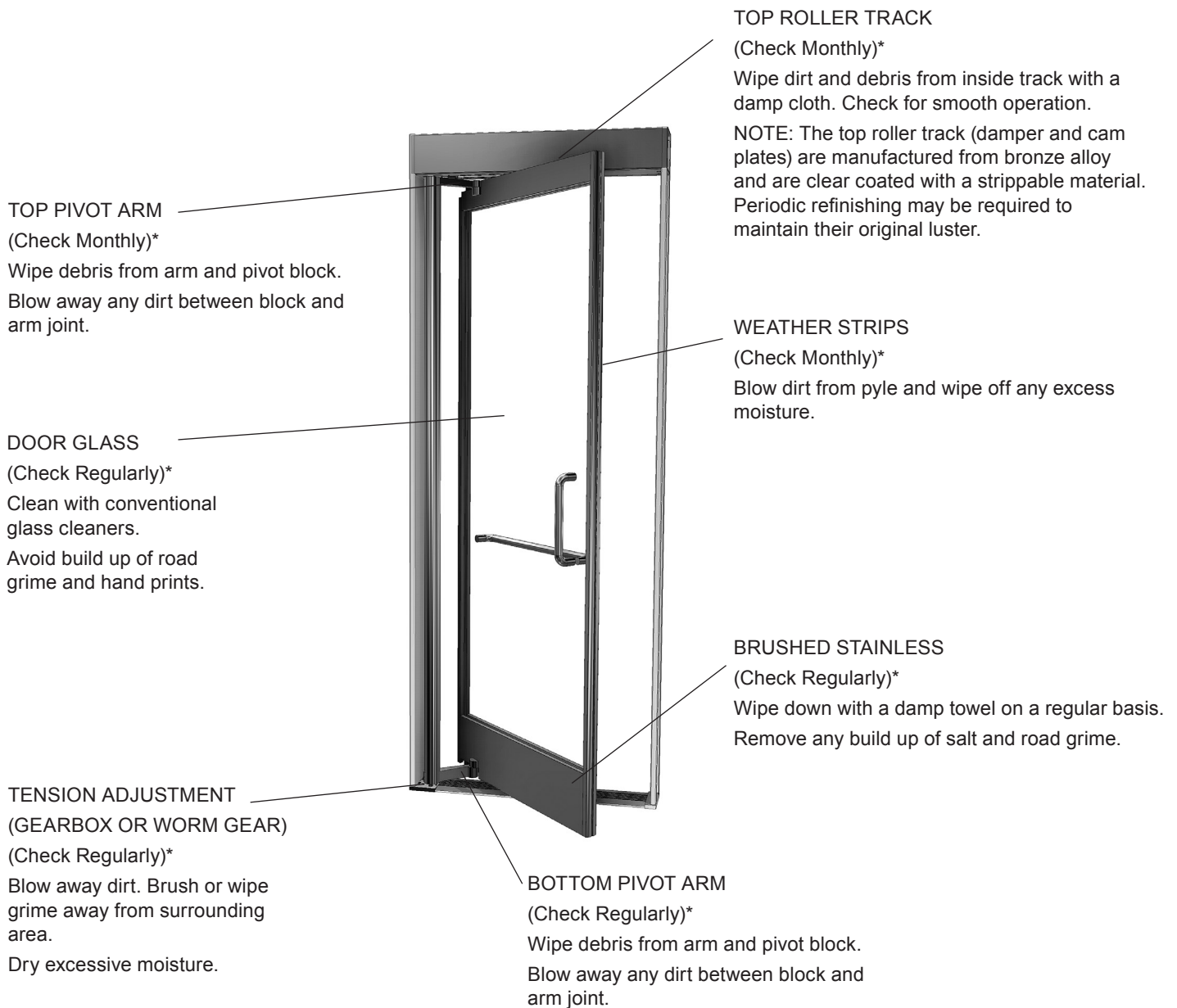

*Inspection intervals are suggestions. Inspection and maintenance should be based on actual cycle levels and environmental conditions.



JOB SITE ESSENTIALS

Helpful Tools and Supplies for Installing CRL U.S. Aluminum Entrances, Storefronts, Windows, and Curtain Wall Systems



CRL Electronic Level and Angle Locator with Digital Display
CAT. NO. 406065

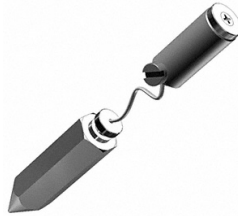

CRL Plumb Bob Alignment Tool for Premium Balanced Doors
CAT. NO. BDPS105



CRL .34 Fl. Oz. (10 ml) Tube Loctite® Threadlocker
CAT.NO. 24221



CRL Glass Cleaner
CAT. NO. 1973



CRL Glass Wipes
CAT. NO. 1550



CRL Silicone Building Sealant
CAT. NO. 95C

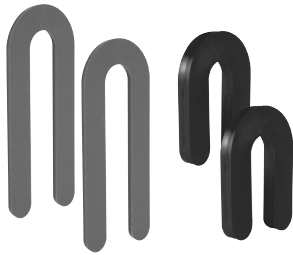

CRL Plastic Horseshoe Shims
CAT. NO. PHS18



CRL Wood's Powr-Grip® 8" Vacuum Cup
CAT.NO. W4950



CRL 12:1 Ratio Strap Frame Caulking Gun
CAT. NO. GA1203



CRL Modified Smooth Polyurethane Construction Sealant
CAT. NO. M64GRY



CRL Modified Grainy Polyurethane Construction Sealant
CAT. NO. M66

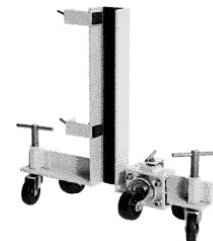

CRL Door Jack
CAT. NO. DJ1