

INSTALLATION INSTRUCTIONS

SERIES IW8200

HURRICANE RESISTANT HORIZONTAL
SLIDING WINDOW BLOCK OR FIN FRAME

Storm Front™

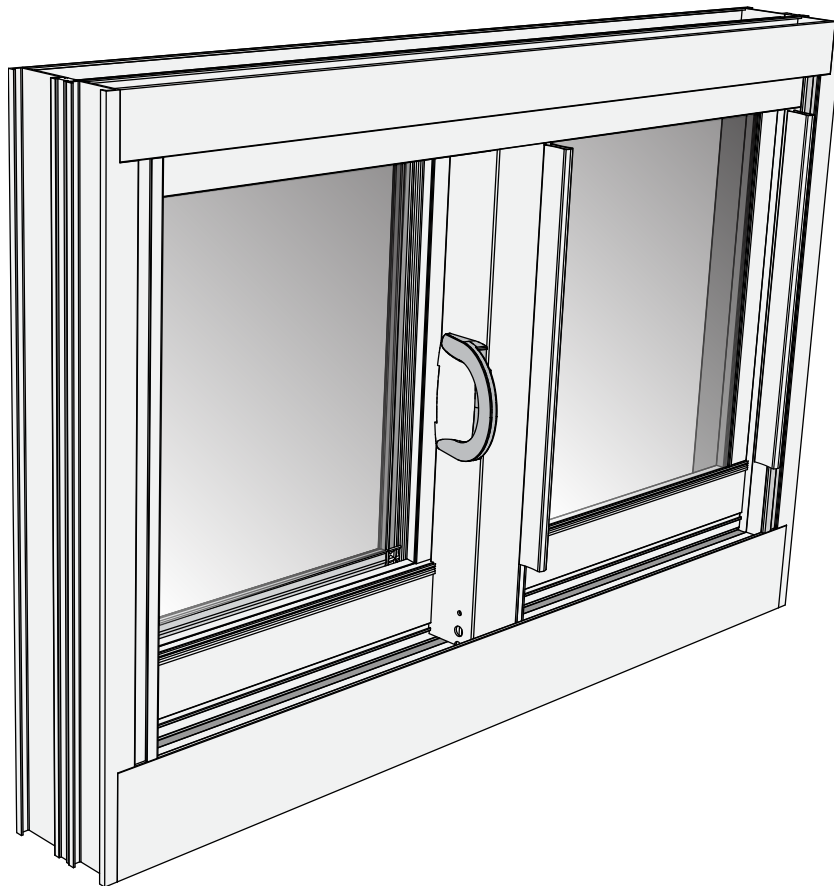

Phone: (800) 262-5151 • Fax: (866) 262-3299
crlaurence.com • usalum.com • crl-arch.com

HANDLING, STORAGE, AND PROTECTION OF ALUMINUM

The following precautions are recommended to protect the material against damage. Following these precautions will help ensure early acceptance of your products and workmanship.

A. HANDLE CAREFULLY.

All aluminum materials at job site must be stored in a safe place, well removed from possible damage by other trades. Cardboard wrapped or paper interleaved materials must be kept dry.

B. CHECK ARRIVING MATERIALS.

Check for quantity counts and keep records of where various materials are stored.

C. KEEP MATERIALS AWAY FROM WATER, MUD, AND SPRAY.

Prevent cement, plaster, or other materials from damaging the finish.

D. PROTECT THE MATERIALS AFTER ERECTION.

Protect erected frame with polyethylene or canvas splatter screen. Cement, plaster, terrazzo, other alkaline solutions, and acid based materials used to clean masonry are harmful to the finish. ***If any of these materials come in contact with the aluminum, immediately remove with water and mild soap.***

The rapidly changing technology within the architectural aluminum products industry demands that U.S. Aluminum reserve the right to revise, discontinue or change any product line, specification or electronic media without prior written notice.

NOTE: Dimensions in parentheses () are millimeters unless otherwise noted.

GENERAL INSTALLATION NOTES

RECOMMENDED GUIDELINES FOR ALL INSTALLATIONS:

- 1. REVIEW CONTRACT DOCUMENTS.** Check shop drawings, installation instructions, test reports, architectural drawings, and shipping lists to become thoroughly familiar with the project. The shop drawings take precedence and include specific details for the project. Note any *field verified* notes on the shop drawings prior to installing. The installation instructions are of a general nature and cover most conditions. **NOTE:** Calculations and dimensions on shop drawings take precedence over installation instructions.
- 2. INSTALLATION.** All materials are to be installed plumb, level, and true.
- 3. BENCH MARKS.** All work should start from bench marks and/or column lines as established by the architectural drawings and the general contractor with guaranteed accuracy. Working from these datum points and lines determine:
 - a) The plane of the wall in reference to offset lines provided on each floor.
 - b) The finish floor lines in reference to bench marks on the outer building columns.
 - c) Mullion spacing from both ends of masonry opening to prevent dimensional build-up of daylight opening.
- 4. FIELD WELDING.** All field welding must be adequately shielded to avoid any splatter on glass or aluminum. Results will be unsightly and/or structurally unsound. Advise general contractor and other trades accordingly. All field welds of steel anchors must receive touch-up paint (zinc chromate) to avoid rust.
- 5. SURROUNDING CONDITIONS.** Make certain that construction which will receive your materials is in accordance with the contract documents. If not, notify the general contractor in writing and resolve differences before proceeding with work.
- 6. ISOLATION OF ALUMINUM.** Aluminum to be placed in direct contact with uncured masonry or incompatible materials should be isolated with a heavy coat of zinc chromate or bituminous paint.
- 7. SEALANTS.** Sealants must be compatible with all materials with which they have contact with (full or incidental), including other sealant surfaces. It is the sole responsibility of the glass company to consult the sealant manufacturer for recommendations regarding joint size, shelf life, compatibility, cleaning, priming, tooling, adhesion, etc. It is the responsibility of the **Glazing Contractor** to submit a statement from the sealant manufacturer indicating that glass and glazing materials have been tested for compatibility and adhesion with glazing sealants, and interpreting test results relative to material performance, including recommendations for primers and substrate preparation required to obtain adhesion. The chemical compatibility of all glazing materials and framing sealants with each other and with like materials used in glass fabrication must be established. ***This is required on every project.***
- 8. FASTENING.** Within the body of these instructions "fastening" means any method of securing one part to another or to adjacent materials. Only those fasteners used within the system are specified in these instructions. Due to the varying perimeter conditions and performance requirements, perimeter and anchor fasteners are not specified in these instructions. For perimeter and anchor fasteners refer to the shop drawings or consult the fastener supplier.
- 9. BUILDING CODES.** Due to the diversity in state/provincial, local, and federal laws and codes that govern the design and application of architectural products, it is the responsibility of the individual architect, owner, and installer to assure that products selected for use on projects comply with all the applicable building codes and laws. U.S. Aluminum exercises no control over the use or application of its products, glazing materials, and operating hardware, and assumes no responsibility thereof.
- 10. EXPANSION JOINTS.** Expansion joints and perimeter seals shown in these instructions and in the shop drawings are shown at normal size. Actual dimensions may vary due to perimeter conditions and/or difference in metal temperature between the time of fabrication and the time of installation. Gaps between expansion members should be based on temperature at time of installation.
- 11. RACK OR WATER TEST.** As soon as a representative amount of the wall has been glazed (500 square feet or 46.5 m²) a rack or water test should be conducted in accordance with AAMA 502-08 specifications to check the installation. On all jobs the rack or water test should be repeated every 500 square feet (46.5 m²) during the glazing operation.
- 12. COORDINATION WITH OTHER TRADES.** Coordinate with the general contractor any sequence with other trades which offset curtain wall installation (i.e. fire proofing, back-up walls, partitions, ceilings, mechanical ducts, converters, etc.).
- 13. CARE AND MAINTENANCE.** Final cleaning of exposed aluminum surfaces should be done in accordance with AAMA 609.1 for anodized aluminum and 610.1 for painted aluminum.
- 14. JOB SITE ESSENTIALS.** See pages 17 and 18.

SITE PREPARATION

BEFORE INSTALLATION

1. Review and measure the opening.
2. Verify rough window opening size 1/2" (12.7) clearance in both width and height to the window. Verify framing is plumb, straight, and true around window opening. Measure opening at each end and at center vertically and horizontally. Make corrections to openings as required. Measure opening diagonally to check squareness. Chip concrete high points to flush and rounded corners to square.

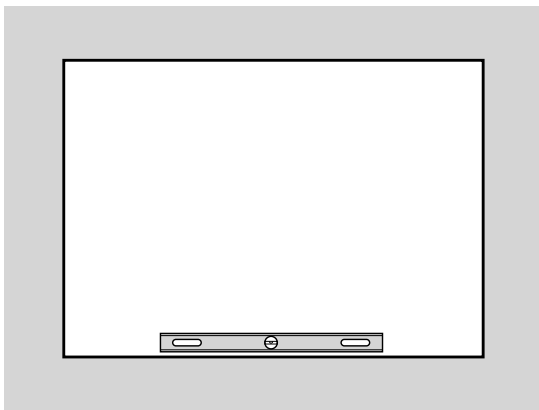

LEVEL

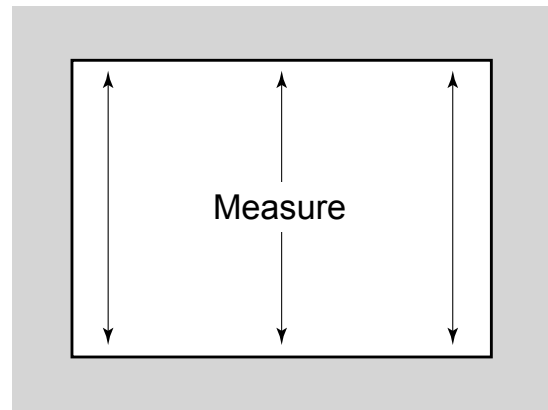

VERTICAL DIMENSION

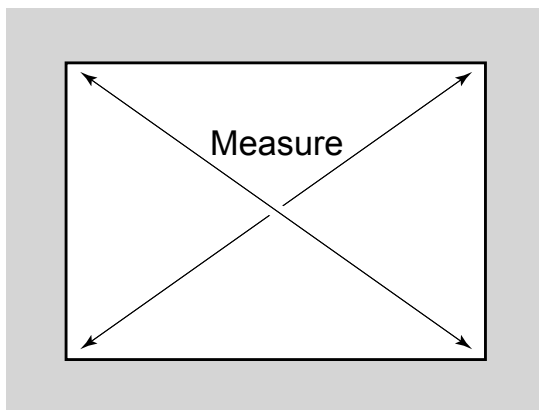

SQUARE

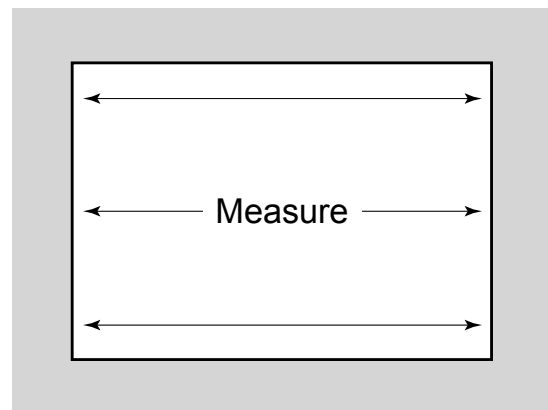

HORIZONTAL DIMENSION

FRAME INSPECTION

3. Visually inspect all frames upon receipt. Inspect frame corners for any sealant damage and re-apply **CRL RTV408 Silicone Sealant** where required. Check sealant at outside frame corners ①. Open the vent side and inspect seals at inside corners ② at jamb/sill intersection. Check and repair joint between vertical and horizontal anchor flanges if applicable. Inspect Baffles and Weep Gates to assure they have not been jarred loose during shipment.

SASH, GLASS AND OTHER NON-FRAME COMPONENTS ARE NOT SHOWN FOR CLARITY

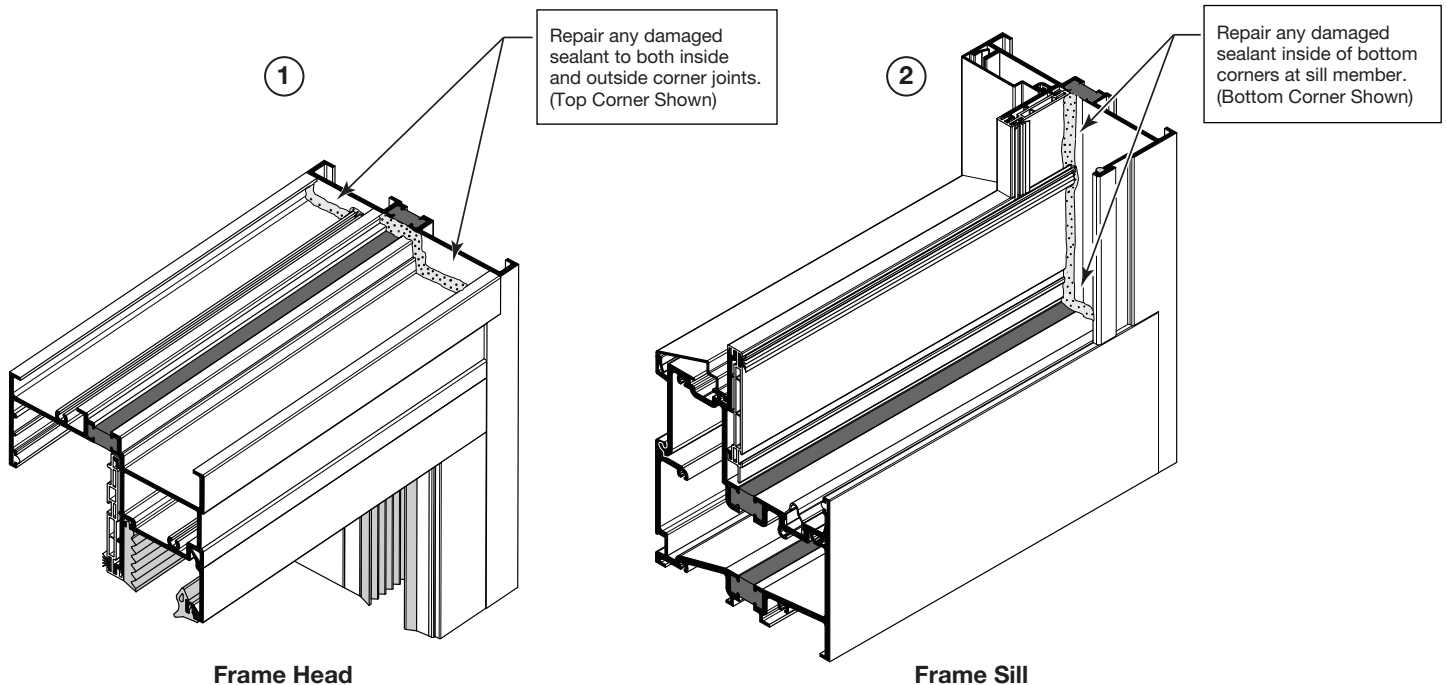
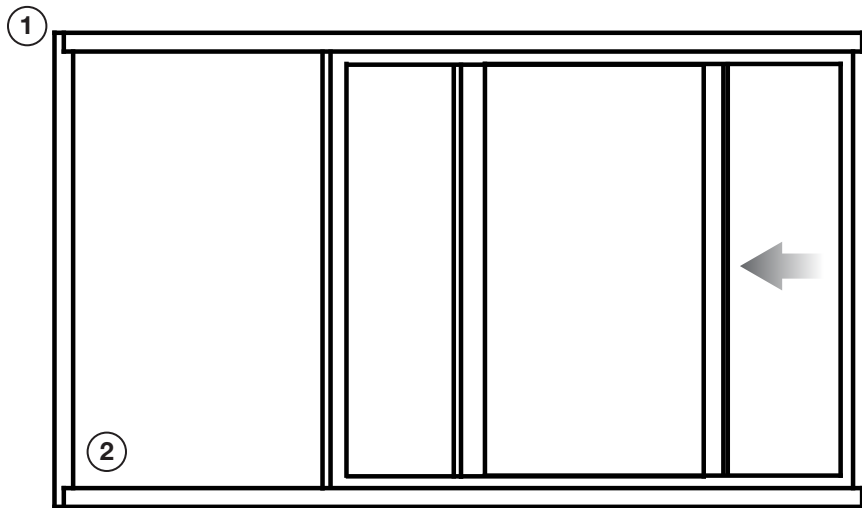

SERIES IW8200 HURRICANE RESISTANT HORIZONTAL SLIDING WINDOW

GENERAL DRY GLAZING PROCEDURE FOR 1-7/32" (31) GLAZING

Step 1: Cut the Interior Glazing Gasket (supplied) to size and insert around the perimeter, sealing all end joints.

Step 2: Place the two Sash Setting Blocks (supplied) at the bottom of the frame and at 1/4 points.

Step 3: Peel off the tape liner and insert one **WB701** Edge Block on each side of the frame.

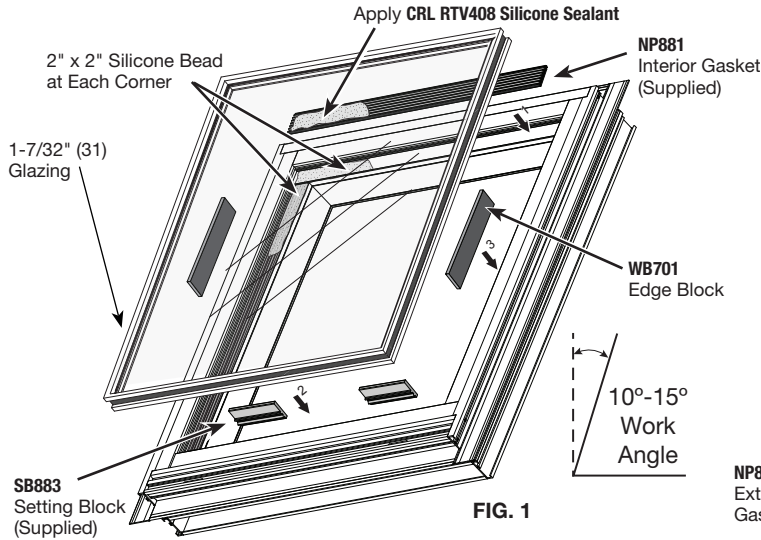

FIG. 1

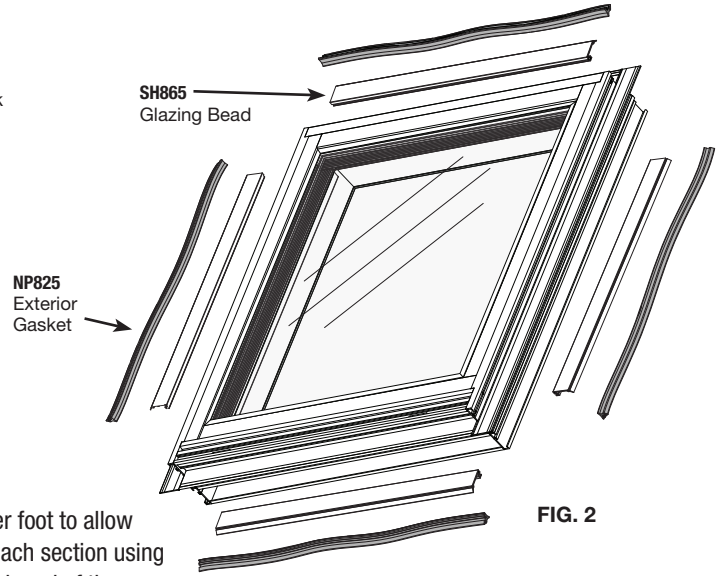

FIG. 2

Step 4: Support the frame at a 10°-15° angle and insert the Glass Panel, working it into position against the frame blocks **Figure 2**

Step 5: Cut and insert each **SH865** Glazing Bead. **Figure 3**

Step 6: Cut the **NP825** Exterior Gasket for all four sides 1/8" (3.2) longer per foot to allow for shrinkage and bevel cut the ends to assure a good seal. Insert each section using **Figure 4** as your guide. Apply **CRL RTV408 Silicone Sealant** to each end of the gasket as it is installed.

Step 7: Seal Exterior of the Beads with **CRL RTV408 Silicone Sealant**

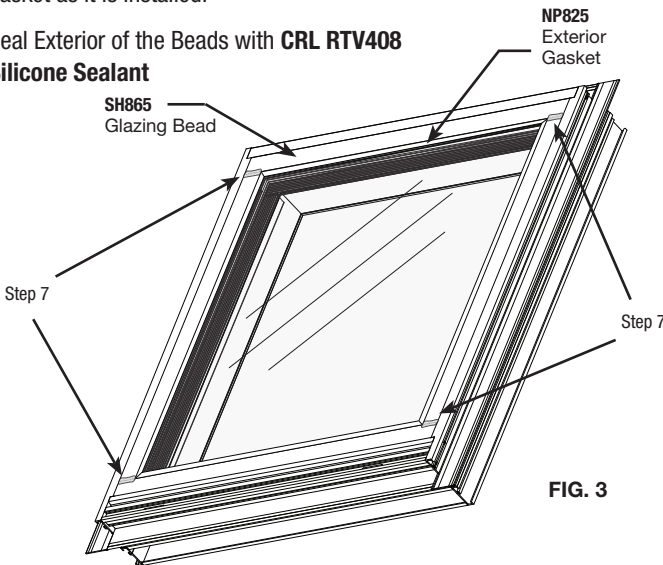

FIG. 3

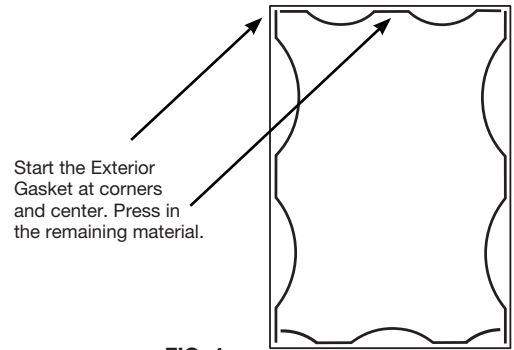

FIG. 4

Start Sill Gaskets at Setting Blocks.

For the best results:

Remove the gasket material from carton and lay flat in a clean dry area for at least two hours at a temperature above 50°F (10°C) to allow gaskets to recover their shape.

Glaze with gaskets above 40°F (4°C). If necessary warm gaskets before installing. Cut gaskets a minimum of 1/8" (3.2) longer per foot than aluminum extrusion.

Do not stretch gaskets to make them fit. It is very important that gaskets are crowded-in and installed correctly.

Corner between gaskets must be cut at correct bevel (miter) to result in a good joint. See **Figure 5**.

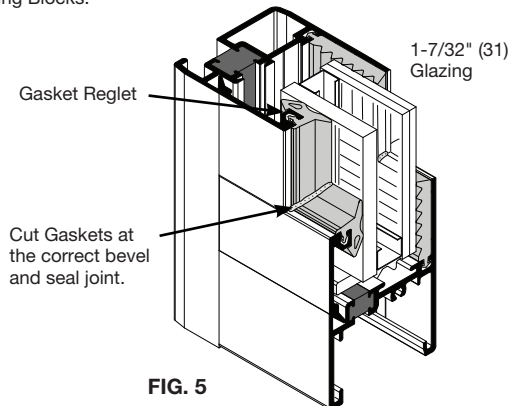
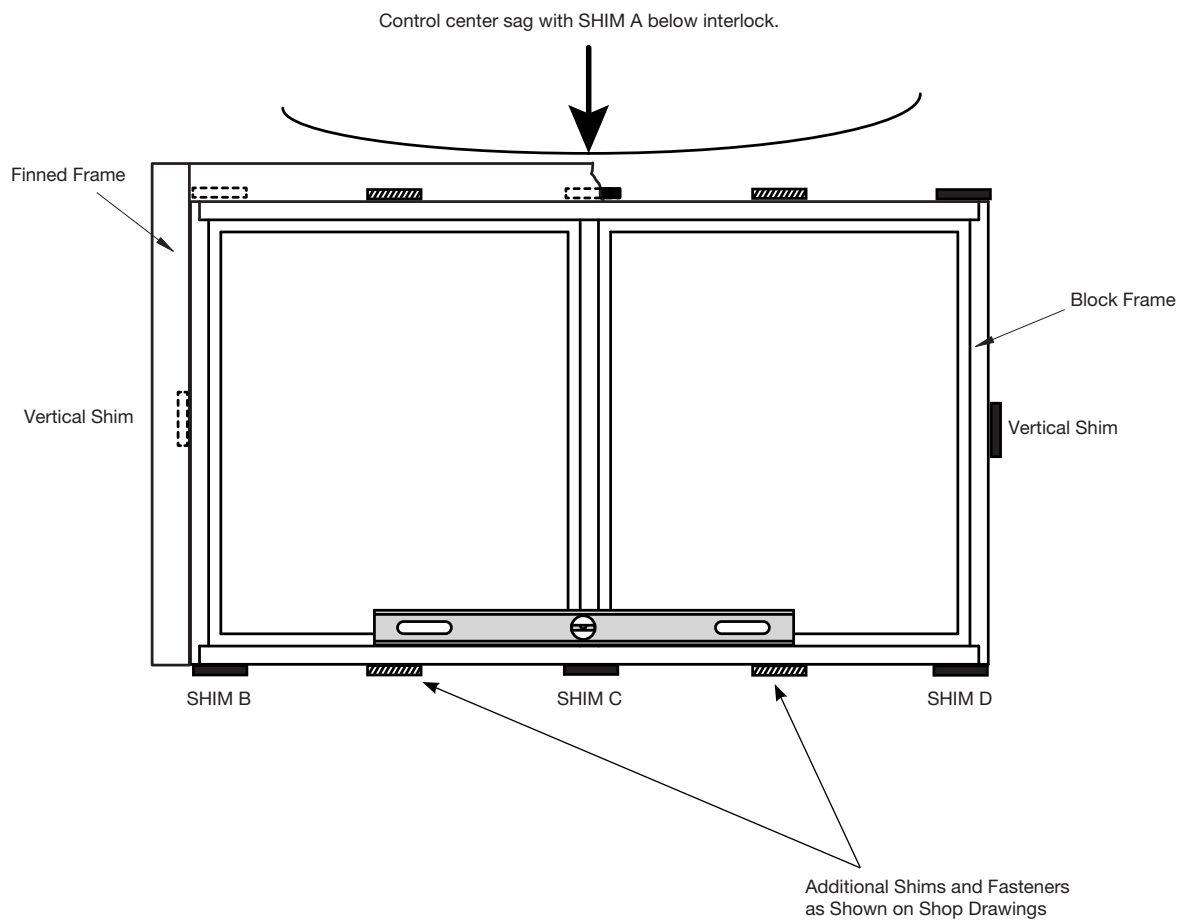

FIG. 5

CORRECT USE OF SHIMS

Shims are required to hold the window level and plumb during the fastening and sealing process (See Jobsite Essentials). They should be used on both the block and finned frames.

1. Close and lock sliding vent.
2. Insert Shims B, C, and D below window sill and adjust until it is level and centered in the opening. Check top rail for sag and correct if necessary by adjusting Shim A.
3. Insert a fastener through sill and Shim A into the opening structure.
4. Insert the Vertical Shims on each side and check for plumb.
5. Add properly spaced Top Shims to snug window in opening.
6. Continue to fasten window to opening by driving screws through window frame and shims. Seal over joints and all screw heads as shown on Page 08.



PAN FLASHING FOR BLOCK FRAME WINDOW INSTALLATION:

NOTE: Window MUST be level and square to function properly. Pan flashing design and installation method is not determined by or warranted by U.S. Aluminum, unless provided by U.S. Aluminum by special order. Consult Tech Sales for details. Refer to approved project shop drawings for scope and intent of pan flashing requirements.

1. Set flashing in full bed of **Cat. No. 95C/M64/M66 Sealant**, centered in opening.
2. Anchor Sill into position using fastener type as indicated in approved shop drawings.
3. Seal any joints or gaps and tool smooth.

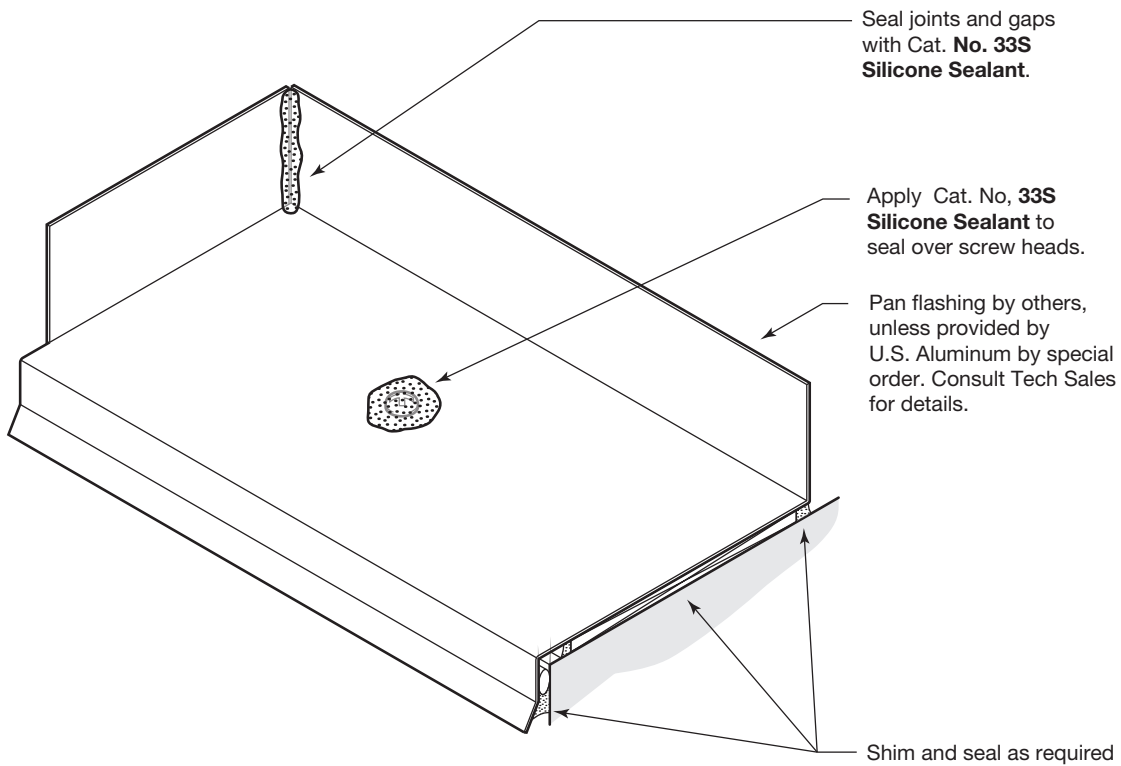

NOTE: Consult Sealant Manufacturer for Proper Cleaning and Priming Recommendations

BLOCK FRAME WINDOW INSTALLATION FOR 1-7/32" (31) GLAZING

1. Place window unit into opening, shimming at jambs to plumb. If using an extruded subsill, run an interior bead of **Cat. No. 95C/M64/M66 Sealant** at the base of the Subsill Flange and End Dams before inserting window frame.
2. An Anchor Trim, **Cat. No. SH886**, is available for the Series 8200 Window. If using the Anchor Trim method, seal the exterior side of the Anchor Trim before inserting the window using **Cat. No. 95C/M64/M66 Sealant** (See illustration below). Insert window while sealant is wet forming a water tight barrier.
3. Anchor the Head, Sill, and Jambs to substrate using one of the methods shown below.
4. If using Anchor Trim, **Cat. No. SH886**, fasten window frame to trim. See shop drawings for fastener types and spacing. Seal screw heads with **Cat. No. 33S Silicone Sealant**.
5. Install **Cat. No. PW803 Jamb Filler** and **Cat. No. SH885 Anchor Trim Cover** (optional). Cut covers to length as required.
6. Add Backer Rod, then apply **Cat. No. 95C/M64/M66 Sealant** to interior and exterior perimeter at Head, Jambs, and Sill.

*** NOTE:** Size and spacing of Anchor Fasteners to be determined by structural engineer.

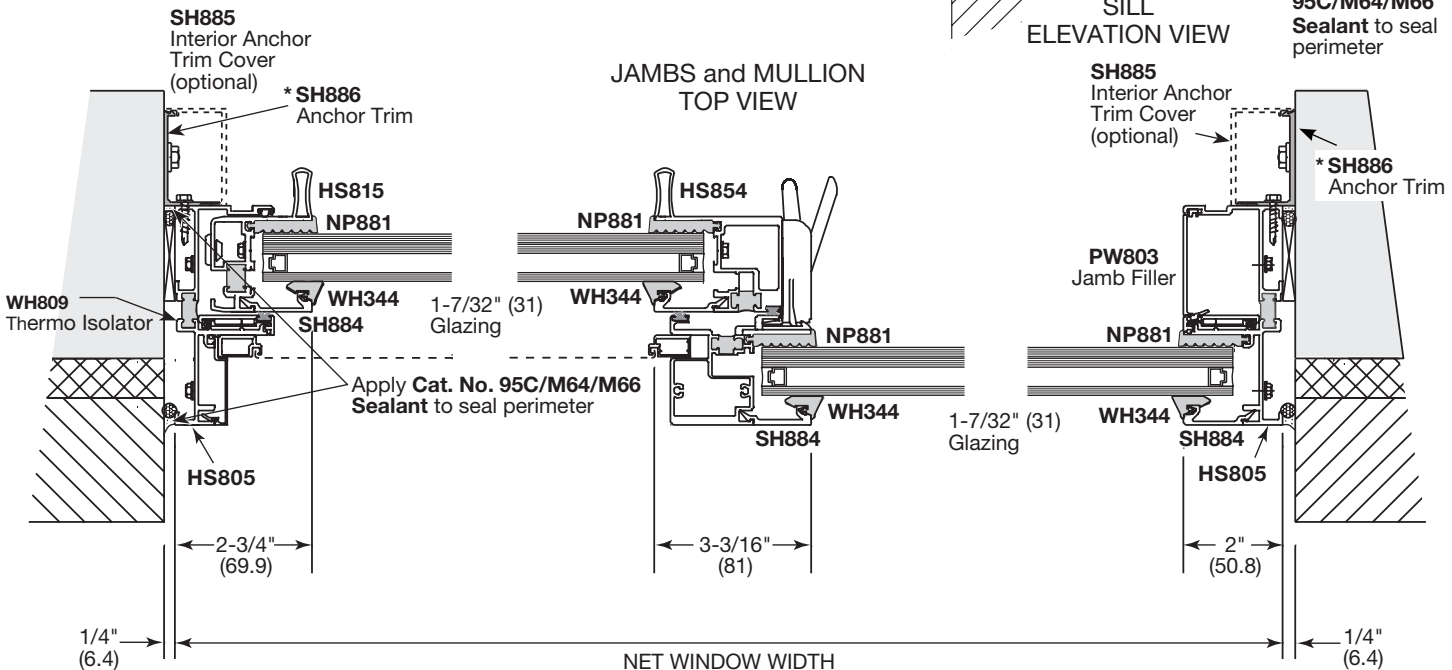
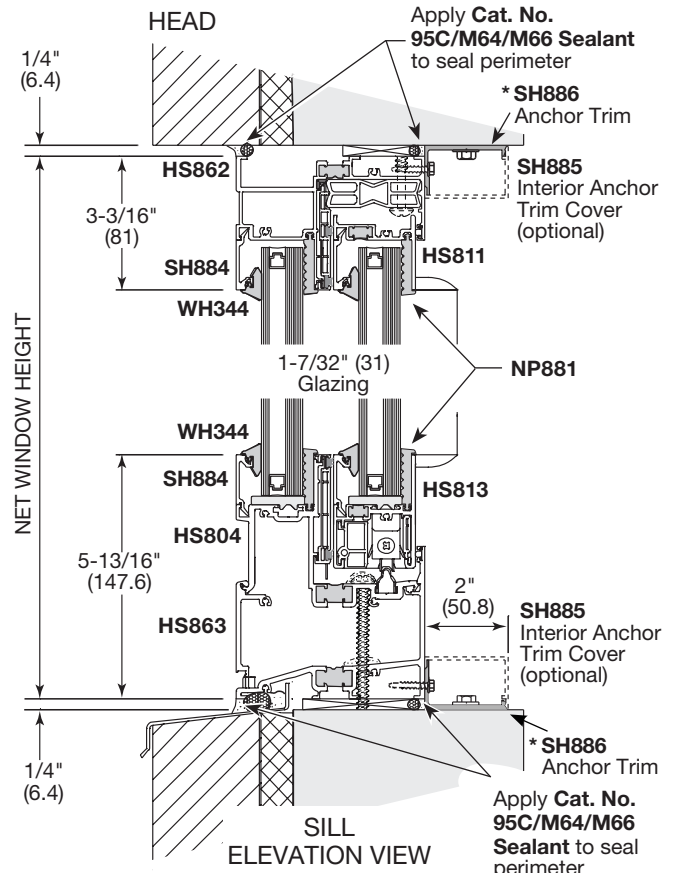

**FIN FRAME WINDOW INSTALLATION
FOR 1-7/32" (31) GLAZING**

1. The prepared opening should be 1/4" (6.4) larger on all sides than the window unit.
2. Follow the AAMA "A" or "B" flashing method.
3. An Anchor Trim, **Cat. No. SH886**, is available for the Series 8200 Window. Secure the Anchor Trim to the substrate at the Head, Jambs, and Sill with fasteners. After installing the trim, seal the exterior facing side of Anchor Trim before inserting the window using **Cat. No. 95C/M64/M66 Sealant** (see illustration below). Insert window while sealant is wet, forming a water tight barrier.
4. Anchor Head, Sill, and Jambs to substrate using method shown below. When anchoring through Head, Jamb, or Sill members, shims must be located at anchor points. Seal screw heads with **Cat. No. 33S Silicone Sealant**.
5. Install **Cat. No. PW803** Jamb Filler and **Cat. No. SH885** Anchor Trim Cover (optional). Cut covers to length as required and snap over Anchor Trim.
6. Add Backer Rod, then apply **Cat. No. 95C/M64/M66 Sealant** to interior and exterior perimeter at Head, Jambs, and Sill.

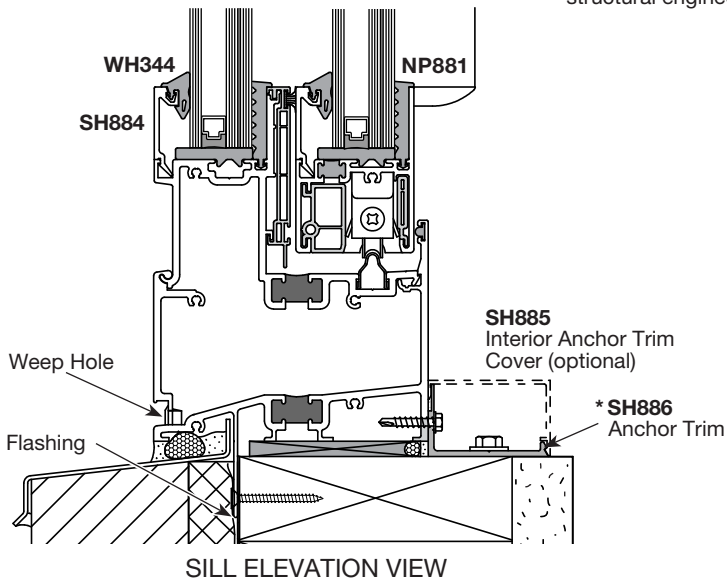
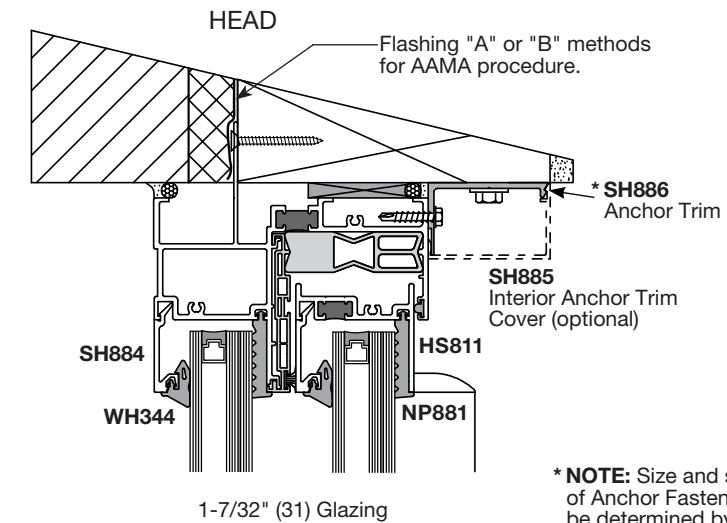

* NOTE: Size and spacing of Anchor Fasteners to be determined by structural engineer.

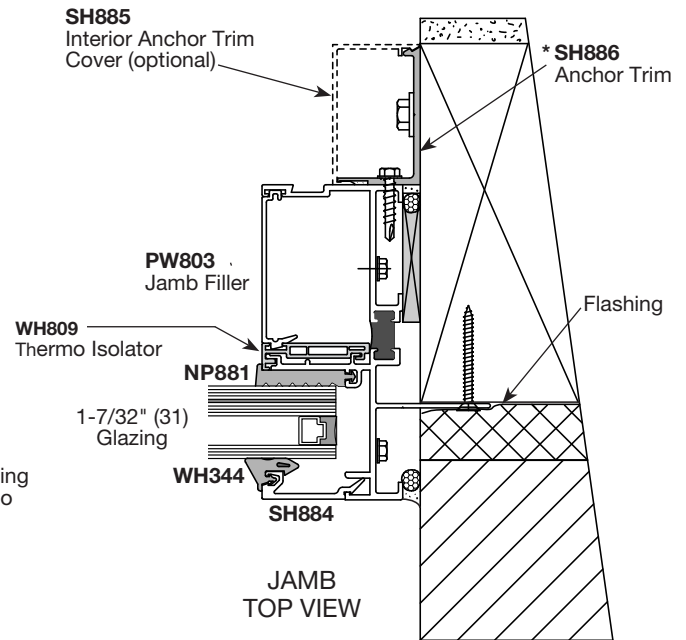

Cutting Anchor Trim:
 Horizontal Anchor Trim: = Rough Opening.
 Horizontal Trim Cover (optional): = Rough Opening.
 Cut Vertical Anchor Trim: = Rough Opening minus 2-1/2" (63.5).
 Cut Vertical Trim Cover (optional): = Field cut cover to size (Runs between horizontal trim covers).
 Fab frame attachment holes: = Drill 3/16" dia. holes for #8 Pan Head Sheet Metal Screws (by others). Consult shop drawings for location and spacing.

MULTI-WINDOW OPENINGS FOR BLOCK FRAME WINDOW:

1. Starting at one end, place first window unit into opening, shimming at jamb to plumb.
2. Anchor jamb to substrate using method shown in shop drawings. When anchoring with interior Anchor Trim, interior perimeter seals must be applied prior to Anchor Trim. Shim trim angle as required to align with window as shown in shop drawings and anchor to substrate with required fasteners.
NOTE: When using the internal Anchor Trim at head and sill, it is to be installed after all units are in place within opening and runs continuous. See Step 8 below.
3. Insert Mullion onto open Jamb. With Mullion pressed firmly against frame Jamb, match drill for appropriate screw types and attach bottom angle clips to Mullion and Subsill, Pan Flashing or building structure. Refer to approved shop drawing for screw types.
4. Match drill and attach top angle clip to Mullion flush with end just below Mullion End Dam. Shim between top clip and structure. Secure with screws as shown in approved shop drawings.
Use caution not to damage End Dam sealant.
5. Install next window unit positioning against Mullion. Attach to Mullion and sill structure as described above in previous steps.
6. Continue steps until all units are in place and last unit is secured at wall jamb in same manner as first window unit.
7. Apply **Cat. No. 95C/M64/M66 Sealant** to interior perimeter seal at head prior to installing Head Anchor Trim.
8. Position Anchor Trim Angle at head and/or sill interior. Shim as required to align with window as shown in shop drawings and anchor to substrate with required fasteners.
9. Screw attach Anchor Trim to window frame. See shop drawings for fastener types and spacing. Seal screw heads with **Cat. No. 33S Silicone Sealant**.
10. Install **Cat. No. PW803** Jamb Filler and **Cat. No. SH885** Anchor Trim Cover (optional). Cut covers to length as required and snap over Anchor Trim.
11. Apply **Cat. No. 95C/M64/M66 Sealant** to exterior perimeter at head and jambs.
12. Apply remaining interior perimeter seals to jambs.

NOTE: All perimeter screw heads that penetrate frame members must be sealed with Cat. No. 33S Silicone Sealant.

MULTI-WINDOW OPENINGS FOR BLOCK FRAME WINDOW FOR 1-7/32" (31) GLAZING

13. Pay close attention to sealing area where Pressure Bar traps window frame sill member. Apply bed of **Cat. No. 33S Silicone Sealant** at bottom of Pressure Bar where it contacts with sill's interior vertical leg. **Perimeter seals will be critical and must form a water tight condition between window units.**

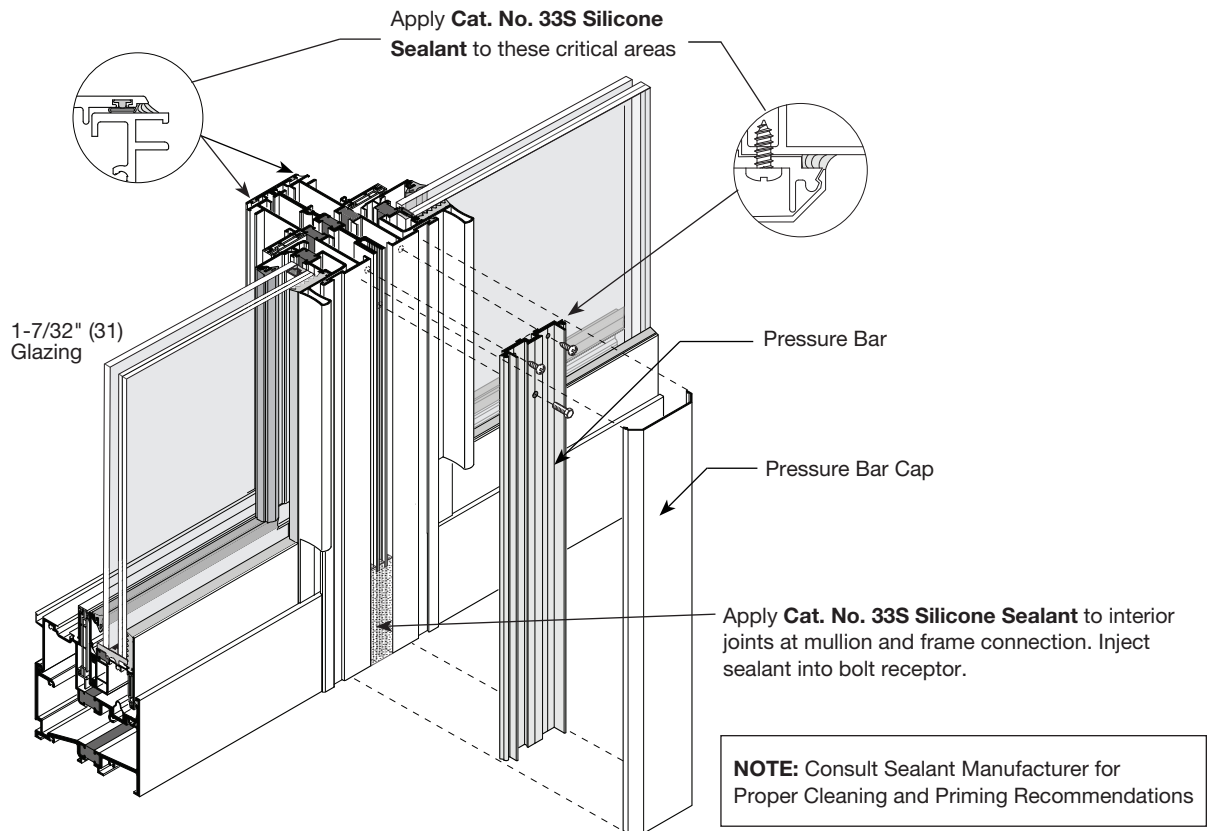

14. Center Pressure Bar vertically on exposed window jambs. Attach Pressure Bar to Mullion with **Cat. No. MS222** 1/4-20 X 1" HWH Screw. Spacing to be from shop drawing.
15. Connect Mullion assembly and window frame jambs together with screws indicated in shop drawings.
16. Fill interior and exterior reveals where window frame and Mullion join as shown using **Cat. No. 33S Silicone Sealant**.
17. Snap interior Mullion Cap onto Pressure Bar. Use caution to avoid denting cap.

INTERIOR ANCHOR TRIM

1. Position Anchor Trim **Cat. No. SH886** around frame perimeter. Shim as required to align with frame. Attach to substrate with fasteners as shown in shop drawings.
2. Apply an interior perimeter seal, using **Cat. No. 95C/M64/M66 Sealant**, to the exterior side of the Anchor Trim prior to installing the window frame. Sealant should be wet when window units are set into place.
3. Screw window frame to Anchor Trim, **Cat. No. SH886**. See shop drawings for fastener types and spacing. Apply **Cat. No. 33S Silicone Sealant** to seal screw heads.
4. If installing **Cat. No. SH885** Trim Snap Covers (optional), field cut covers to length as required and snap over Anchor Trim. **NOTE:** Horizontal covers run through and vertical covers run between.

NOTE: Interior Anchor Trim must be installed prior to installing Mullion Pressure Bar and Cap.

FLASHING FOR FIN FRAME WINDOW INSTALLATION

Step 1: (Methods A and B)

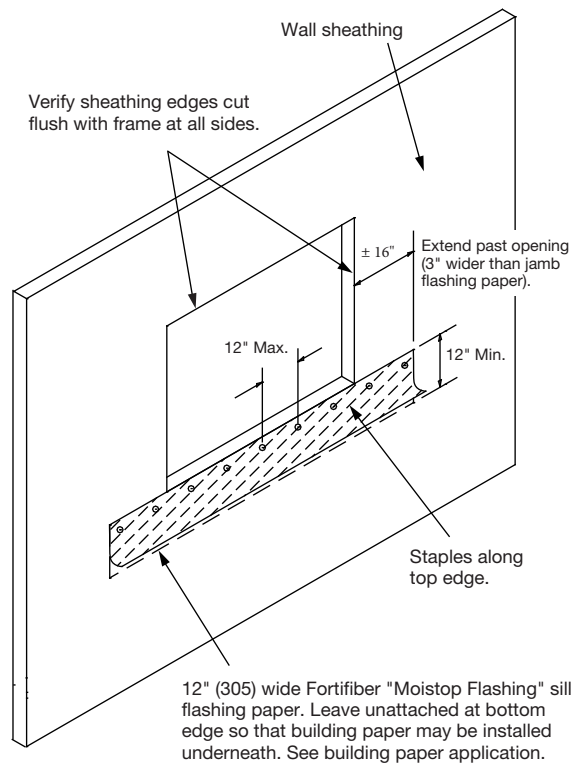

NOTE: Corrosion-resistant staples may be stainless steel or copper with 3/8" (9.5) leg for window flashing.

INSTALLATION INSTRUCTIONS

ERECTION: Add 1/2" (12.7) to height and width of opening for clearance. All window frames shall be set in a level, plumb, and square condition without distortion.

Do not let twin and triple units sag in center of sill during installation. Install shims at corners and center of sill before setting window in opening.

Panels must be installed without forcing, springing or bowing. Close and lock operating sash of window to prevent damage.

Units shall be properly caulked to prevent water leakage around the frame.

Fasteners must be driven straight into wall, not at an angle. Power nailers are not recommended since tool is sometimes held at an angle causing bowed frames.

After installation, the General Contractor shall be responsible for protecting the units during the balance of construction. Upon completion of construction, the General Contractor shall be responsible for cleaning the aluminum and glass without the use of abrasive agents.

CLEANING INSTRUCTIONS: Use household glass cleaner and/or a mild detergent. Steel wool, abrasive cleaner or wire brushes are harmful to the glass and finish of the aluminum. Semiannual cleaning of the wool pile weatherstrip and weep holes in sill will assure proper insulation and drainage.

CAUTION: Spraying with petroleum base material may result in INSULATING GLASS failure and will void glass warranty.

FLASHING FOR FIN FRAME WINDOW INSTALLATION

Step 2: (Method A)

Seal the sill of the window frame to opening. Apply **Cat. No. 95C/M64/M66 Sealant** continuous seal on backside (interior) window sill flange.

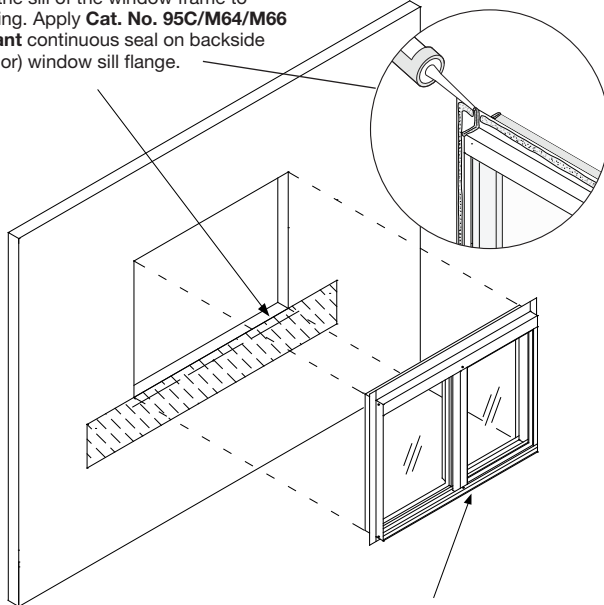

Shim and adjust window to achieve square, plumb, and level condition use corrosion resistant fasteners. Fasten within 10" and no closer than 5" in each direction from every corner. Secure window around frame opening with equivalent of five fasteners at 15" O.C. maximum.

Step 3: (Method A)

After installation seal all corners of mechanically joined frames. Apply **Cat. No. 95C/M64/M66 Sealant** to seal frame seam juncture.

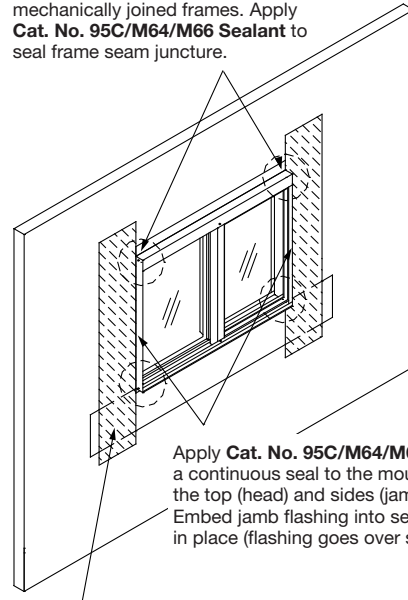

Apply **Cat. No. 95C/M64/M66 Sealant** as a continuous seal to the mounting flanges at the top (head) and sides (jamb) of window. Embed jamb flashing into sealant and fasten in place (flashing goes over sealant).

Extend jamb flashing beyond sill flashing and above where the flashing will intersect.

Step 4: (Method A)

Embed bottom of the head flashing against the previously applied sealant (Flashing goes over sealant). Extend head flashing beyond each jamb flashing. Fasten in place.

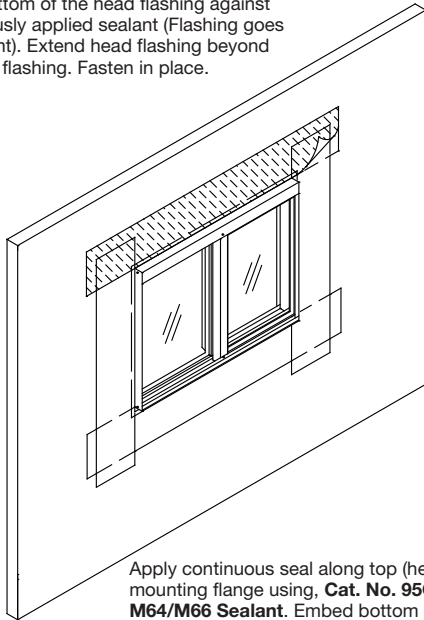

Apply continuous seal along top (head) mounting flange using, **Cat. No. 95C/M64/M66 Sealant**. Embed bottom of head flashing against sealant (flashing goes over sealant). Extend head flashing beyond each jamb flashing. Fasten in place.

Step 5: (Method A)

Where recommended as part of exterior wall finish system, install building paper. Apply weatherboard fasteners starting from bottom to top of wall.

Minimum Vertical laps per code

Install building paper, insulation board or other material over head flashing and over top of nail-on head flange of window frame.

3rd course of building paper

Minimum horizontal laps per code

2nd course of building paper

1st course of building paper

Slip bottom of jamb flashing and sill flashing over building paper and bottom of window sill.

Exterior wall finish: Install per wall finish manufacturer's recommendation. Some exterior finishes may require sealing between the perimeter of the window frame and the exterior finish.

For high performance wind and water. Run a continuous bead of **Cat. No. 95C/M64/M66 Sealant** between the flashing and the window frame.

FLASHING FOR FIN FRAME WINDOW INSTALLATION

Step 2: (Method B)

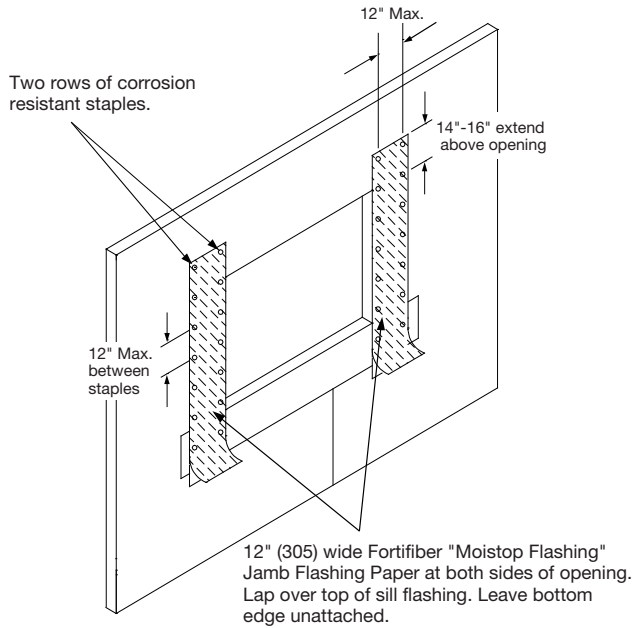

Step 3: (Method B)

Use **Cat. No. 95C/M64/M66** sealant to seal window frame to opening. Apply continuous bead of sealant within 1/2" of edge of opening or the preferred method: Apply continuous sealant on backside of window flanges at head, jamb and sill, then install frame to opening.

NOTE: Check window fins for damage. Repair damaged fins and identify widow for later sill track test.

Place extra sealant at miter corners of window frame. (Backside)

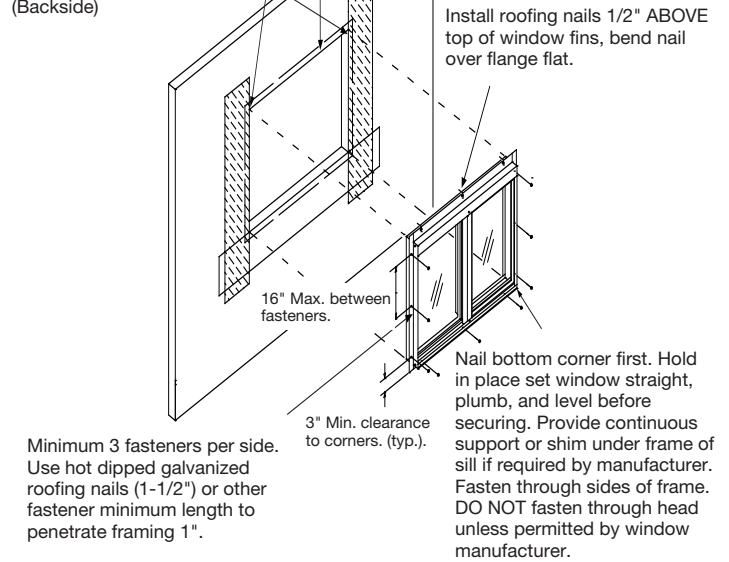

Step 4: (Method B)

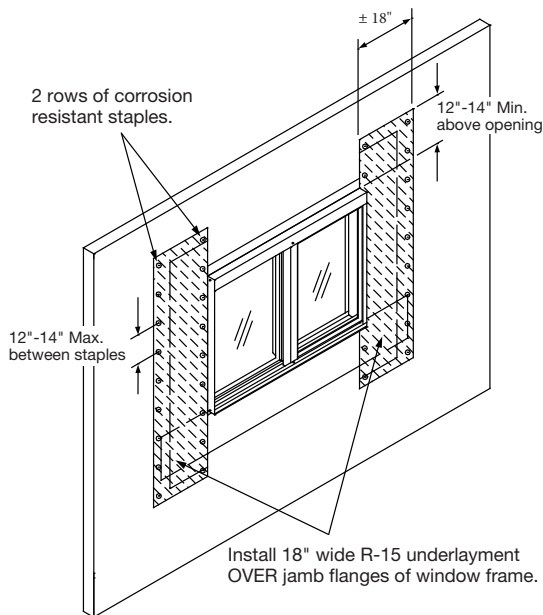

Step 5: (Method B)

1st fortifiber "Moistop Flashing" head flashing paper of flexible membrane. Install head flashing paper OVER nail-on head flange of window frame and over tops of jamb flashing papers.

Extend past opening wider than jamb flashing paper.

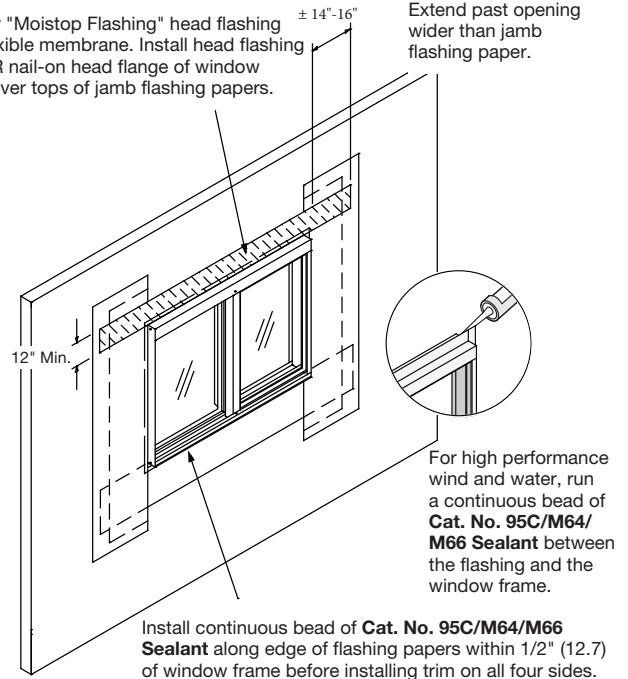



GUIDE TO SEALANTS

NOTE: All sealants must be tooled to ensure proper adhesion.

WATERPROOFING

- **33S ACETIC CURE SILICONE**

Sill to Subsill, End Dams, Screw Heads, and Threshold to Door Frame Sealing.

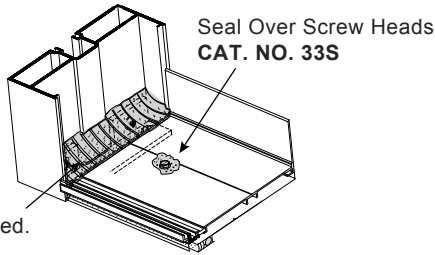

NOTE: Not for use near insulating glass units with butyl sealant.

EXPANSION

- **95C SILICONE BUILDING SEALANT**

Expansion Joints.

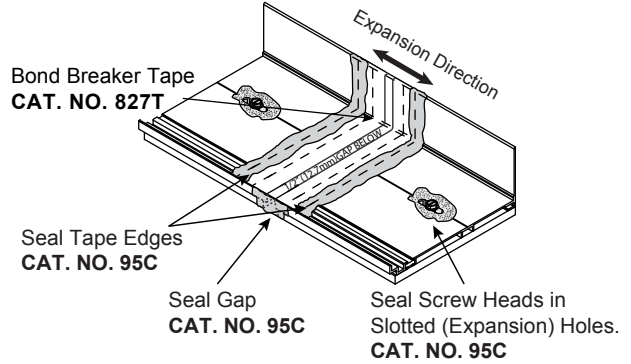

JOINT ADHESIVE

- **RTV408 NEUTRAL CURE SILICONE**

Small Joints, End Joints and Buttered Surfaces, Water Diverters, End Dams and Reglet Fills.

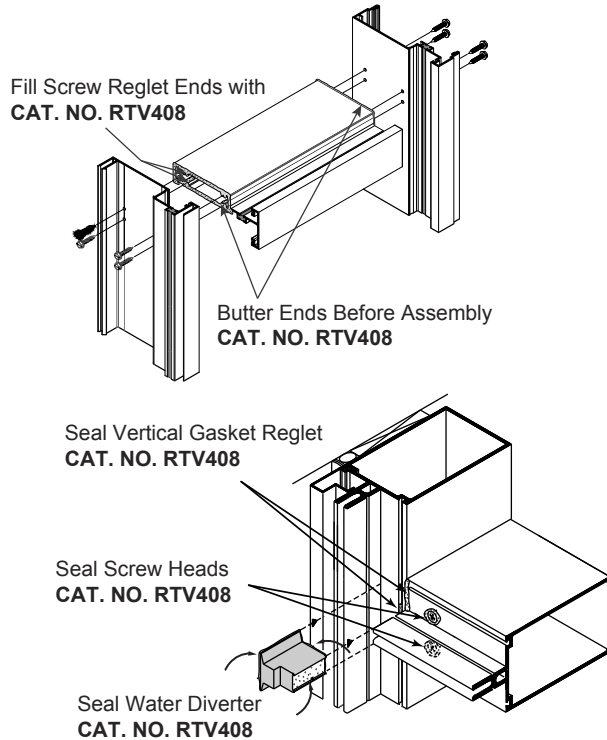

NOTE: I.G. butyl contact OK.

PERIMETER

- **95C SILICONE BUILDING SEALANT (Preferred)**
- **M64 (SMOOTH) MODIFIED POLYURETHANE**
- **M66 (TEXTURED) MODIFIED POLYURETHANE**

Perimeter Seals, Expansion Joints, Sill and Threshold Beds, Concrete, Wood, and Steel Openings.

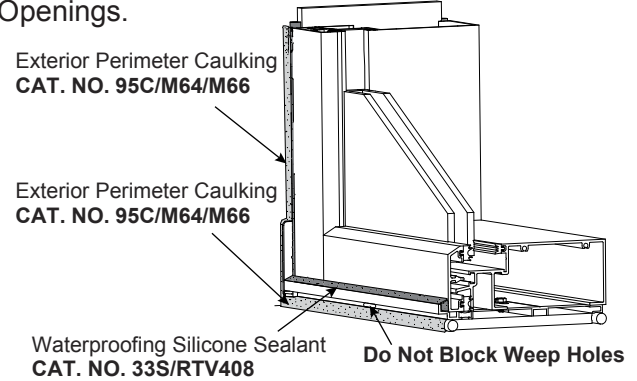

STRUCTURAL

- **ALL STRUCTURAL SEALANTS REQUIRE TESTING AND APPROVAL.**

Glass-to-Glass or Glass-to-Metal



JOB SITE ESSENTIALS

Helpful Tools and Supplies for Installing CRL-U.S. Aluminum Entrances, Storefronts, Windows, and Curtain Wall Systems



CRL 95C Silicone Building Sealant



CRL RTV408 Neutral Cure Silicone



CRL 33S Acetic Cure Silicone



CRL M64 Modified Smooth Polyurethane Construction Sealant



CRL M66 Modified Grainy Polyurethane Construction Sealant



**CRL 12:1 Ratio Strap Frame Caulking Gun
CAT. NO. GA1203**



**CRL Set of Seven All Stainless Steel Spatulas
CAT. NO. AB958G**



**CRL Utility Knife
CAT. NO. K82**



**CRL Backer Rod Roller Tool
CAT. NO. SBRR**



**CRL Soft-Face Power Hitter
CAT. NO. ST57532**



CRL Saint-Gobain/Norton V2100 Thermalbond® Structural Glazing Spacer Tape



**CRL Utility Knife Blades
CAT. NO. 1992C**



CRL PHS Series Plastic Horseshoe Shims

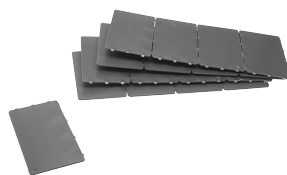

CRL PBS Series Plastic Bearing Shimstrips



**CRL Gloves
CAT. NO. KF1TL**



**CRL Spring Clamp
CAT. NO. JC3202HT**

SERIES IW8200 HURRICANE RESISTANT HORIZONTAL SLIDING WINDOW



CRL Bond Breaker Tape
CAT. NO. 827T34



CRL Glass Cutter
CAT. NO. TC17B



CRL Running Pliers
CAT. NO. PPG1



CRL Vacuum Cup
CAT. NO. S338



CRL Gasket Roller
CAT. NO. VR10

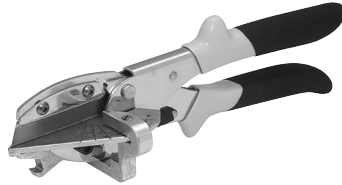

CRL Gasket Cutter
CAT. NO. MC80N



CRL Glass Cleaner
CAT. NO. 1973



CRL Glass Wipes
CAT. NO. 1550



CRL Tape Measure
CAT. NO. 54225

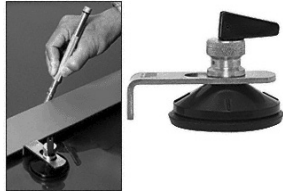

CRL Glazier's Rule Holder
CAT. NO. RH670



CRL Phenolic L Square
CAT. NO. L48



CRL Digital Laser Level Tool
CAT. NO. 406065



CRL Glass Marking Pencil
CAT. NO. GM44



CRL Belt Sander
CAT. NO. LD321



CRL Glass Grinding Belts
CAT. NO. CRL3X21120X



CRL All Terrain Dolly
CAT. NO. ATD1



CRL Hard Hat
CAT. NO. ES3452



CRL Portable Ladder
CAT. NO. 6206



CRL Cordless Screwdriver
CAT. NO. LD823



CRL Cordless Driver/Drill
CAT. NO. LD147